



MAKO[®]

AYDINLATMA
LIGHTINGS 2008

MAGNETI
MARELLI



**MAGNETI
MARELLI**

We illuminate the world...



Dünyaya ışık tutuyoruz...

MAKO[®]



FOG LAMP
SIS LAMBASI

HEADLAMP + TURN INDICATOR
FAR + SINYAL LAMBASI

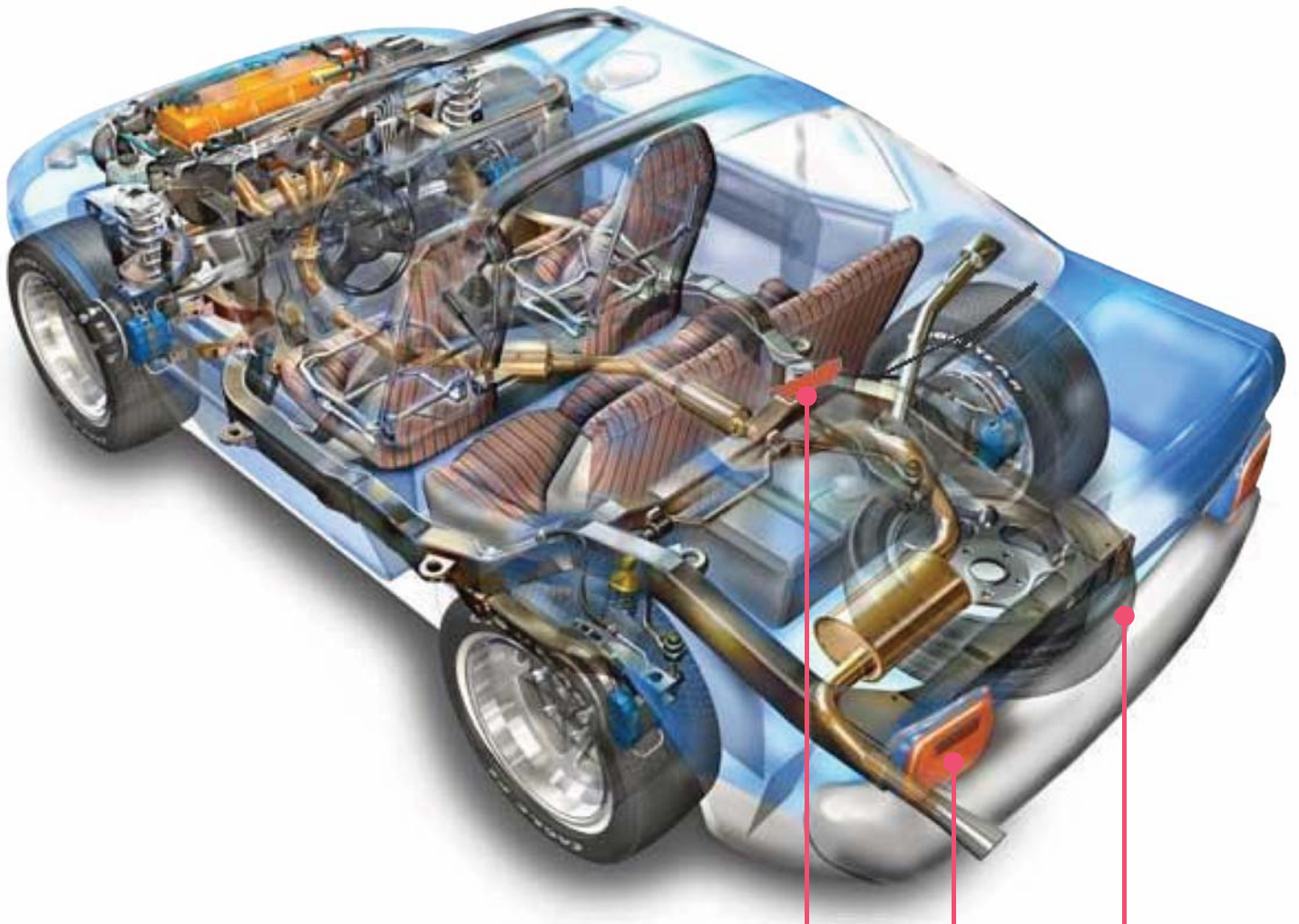

HIGH-MOUNTED STOP LAMP
ÜST STOP LAMBASI

REAR LAMP
STOP LAMBASI

LICENCE PLATE LAMP
PLAKA LAMBASI

Electrical Equipments For Vehicles / Araçlar İçin Elektrikli Cihazlar	2-3
Informazioni Tecniche / Technical information / Teknik Bilgiler	9-19
MAKO's Total Quality Management Approach Milestones	22
MAKO'nun TKY Yaklaşımındaki Kilometre Taşları	23
Manufacturers Index / Müşterilerimiz / Indice Costruttori	23
Legend / Açıklamalar / Legenda	24
Icons / Simgeler / Descrizione icone	29
ALFA ROMEO	33
BMW	34
CHRYSLER	35
CITROËN	36-39
FIAT - TOFAŞ	40-61
FORD	62-65
HEMA	66

HONDA	67
HYUNDAI	68-69
ISIZU	70
MERCEDES	71
OTOKAR	72
OTOYOL / IVECO	73-74
RENAULT	75-77
PEUGEOT	78-81
TOYOTA	82
UZEL	83
VOLVO	84
Cross reference guide / Karşılaştırma tablosu / Tavole di comharazione	89-95
Notes / Notlar	96

Teknik Bilgiler
Informazioni tecniche
Technical Information



Geçen yüzyılın başlangıcından bu yana, özellikle far ve stop lambalarında, otomotiv aydınlatması ile ilgili muazzam teknolojik değişimler meydana gelmiştir.

1912 yılında bir italyan firması olan Carello, Avrupa'da ilk kez bir jeneratör tarafından beslenen elektrikli farı sunmuştur. İlerleyen fazlarda, hem kısa hem de uzun huzme fonksiyonlarına aynı anda izin veren iki filamanlı asimetrik ampüllü farlar geliştirilmiştir.

60'lı yılların başında, Carello firması, yeni bir ampül olan ilk Halogen ampüllü farı sunmuştur. Eski teknolojiye kıyasla (Bilux), bu farlar normal bir fara göre yaklaşık 2 kat daha fazla aydınlık sağlamaktadır. Halogen ampüllerdeki teknik değişimler, farların aydınlatma yeteneğini artırmıştır. Örneğin; H7 ampül kullanımında H4 e nazaran yaklaşık %30 daha fazla bir ışık dağılımına ulaşılabilmektedir.

Performance H4

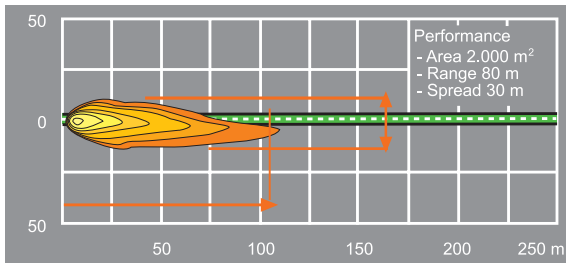

Performance H7

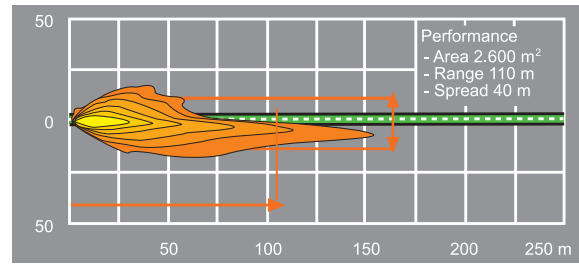

80 li yıllarda diğer taraftan halogen farların ışık yapısını düzenleyen (sonrasında Xenon için) yeni bir teknoloji geliştirilmiştir.

PES teknolojisi (Eliptik lensli farlar)

Bu teknolojiye farın içerisinde ek bir eliptik lens kullanılmaktadır. Bu farın boyutlarına göre daha yüksek bir ışık oluşumuna izin vermektedir. (dağılım ve konsantrasyon olarak)

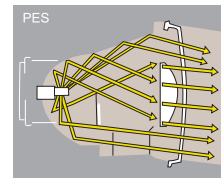
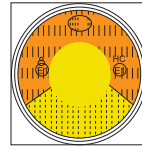
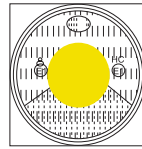
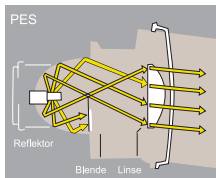

90 lı yıllarda gaz discharge lı ampüllere (D1S, D2S, D1R, D2R olarak bilinen) dayalı Xenon sistemi doğdu. Bu ampüller halogen ampüllere nazaran %200 daha fazla ışık veren ve daha az enerji tüketen ampüllerdir.

Performance H7

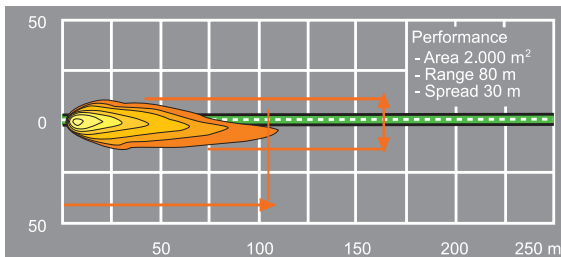

Performance Xenon

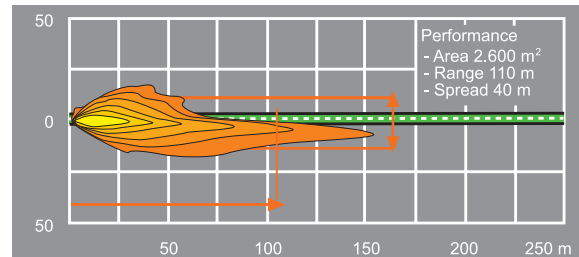

Bu ampüllerin kullanımı daha yüksek far teknolojisi talebini gerektirmektedir. Sadece daha sofistike optik değil, ampül içindeki gazı ateşlemek için gerekli 10.000 / 20.000 volt ulaşmak için elektronik ateşleme ünitesi (ECU) kullanımını gerektirmektedir. Ek olarak, sabit gerilim regülatörü, bir otomatik yük ayarı (far ayar sistemi) ve far yıkama sistemi (Avrupa da kanun gereği) gereklidir.

Bi-Xenon sistemi, bu teknolojinin güncel geliştirilmesi olup, saniyelik dilimde ampül pozisyonunu elektromekanik ayar grubu ile gerçekleştirmektedir. Bu sayede hem kısa hem de uzun hüzme için ışık dağılımı bir ampül ile kontrol edilmektedir.

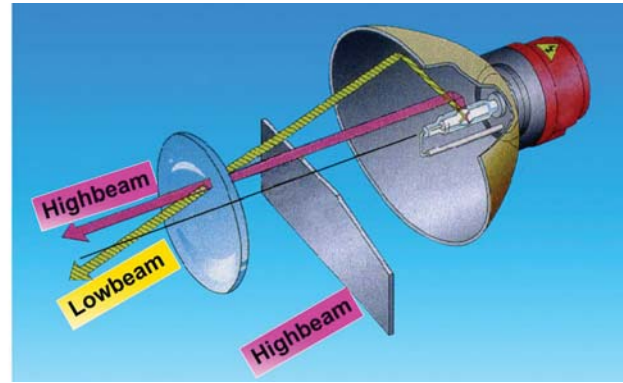
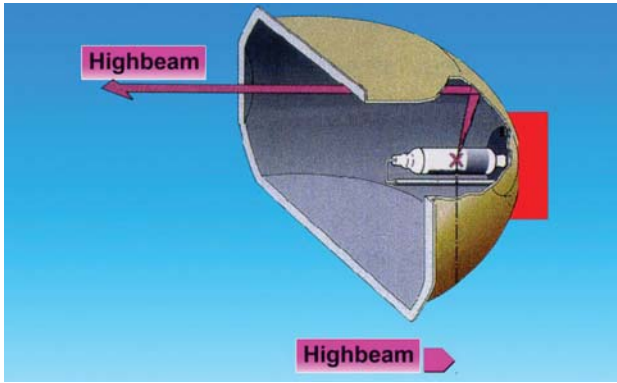

Bir sonraki gelişme SFS (Statik ön aydınlatma sistemi) ve AFS (ayarlanabilir ön aydınlatma sistemi) dir. Daha iyi bilinen viraj aydınlatması, AFS sistemi, (sis-viraj kombinasyonu, statik viraj aydınlatması) daha kolay bir versiyon olup sis lambasının içerisine ilave bir ampül kullanımı ile çalışır. Aydınlatma, sinyal lambası devreye alındığında otomatik olarak devreye girer ve dönüş yapılacak kısımdaki aydınlatmayı artırır.

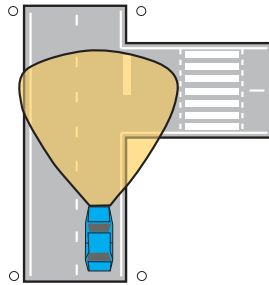

Normal

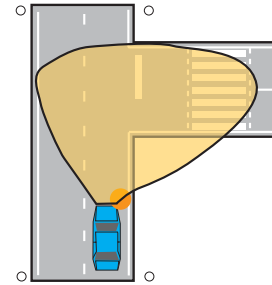

Activation of static curve light in combination with indicator.

Çok daha kompleks olan AFS sistemi dinamik viraj aydınlatmasıdır. Bu sistem, hem yatay hem de dikey olarak otomatik ışık ayarını yönlendirmek amacıyla farklı sensörlerden gelen hız, direksiyon dönüş açısı, vb bilgileri işleyebilen elektrikli bir kontrol ünitesi içermektedir. Önemli kısımların daha iyi aydınlatılması, yüksek sürüş emniyeti sağlamaktadır.

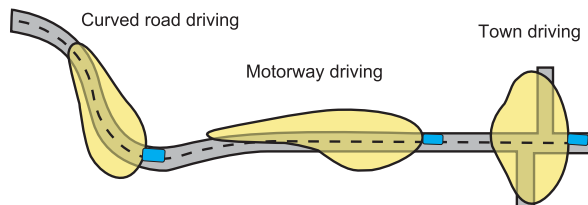

En son gelişme, kızılötesi gece görüş sistemli (kızılötesi destekli gece yardımı) araçların üretimi ile gerçekleştirilmiştir. Bu talep askeriyeden gelmiş olup, farın içerisine entegre edilmiş bir kızılötesi sinyal göndericisi ile birlikte çalışmaktadır. Geri dönen kızılötesi ışınlar, bir elektronik CDD kamera ile resme dönüştürülmekte ve arabanın içerisindeki bir ekranda gösterilmektedir. Gece görüntüsü, insan gözünde, gündüz gibi görünebilir hale getirilmektedir.

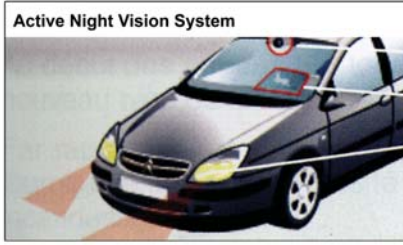

Active Night Vision System

CCD Camera
Display
Lamp

Visible
SceneAdded IR
Display

Arka stoplarla ilgili en son geliştirmeye LED (Işık yayan diyod) teknolojisi kullanımı ile ulaşılmıştır. Bu teknoloji bize çok daha uzun bir ömrün yanı sıra (10.000 saatin üzerinde) çok daha küçük alanlı yeni tasarım imkanları ile birlikte daha az enerji kullanımına müsaade etmektedir.



Lancia Thesis

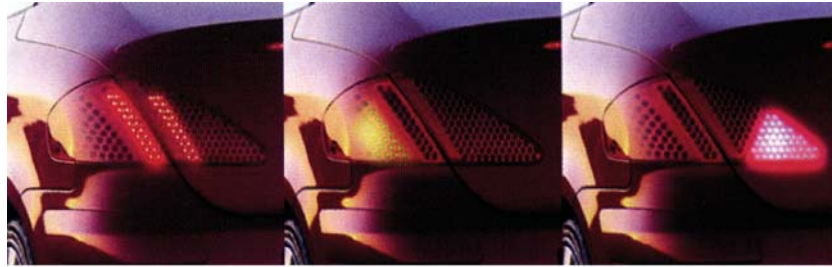

Peugeot 307 C.C.



VW Passat Limousine

Cento anni di evoluzione nell'Illuminazione Automotive



Dall'inizio del '900 sono grandissimi gli sviluppi tecnologici avvenuti nel campo dell'Illuminazione Automotive, soprattutto per il prodotto "proiettori" o "fari".

Nel 1912 l'azienda italiana Carello è la prima in Europa ad introdurre su vettura i **proiettori elettrici alimentati da un generatore**.

La fase successiva è stata lo sviluppo di proiettori con **lampada asimmetrica** a due filamenti, in grado di svolgere contemporaneamente la funzione di luce anabbagliante e di luce abbagliante.

All'inizio degli anni '60 sempre l'azienda Carrello introduce il primo proiettore che utilizza un nuovo tipo di lampada: **la lampada alogena**.

Rispetto alla tecnologia precedente, il proiettore con lampada alogena è in grado di fornire una luce di intensità quasi doppia rispetto ai proiettori che utilizzano normali lampade ad incandescenza.

Lo sviluppo tecnologico delle lampade alogene a sua volta ha incrementato la capacità di generare luce con relativi benefici sulle performance dei proiettori.

Ad esempio l'utilizzo di una lampada alogena H7 al posto di una lampada H4 permette di sviluppare una performance luminosa superiore del 30%.

Performance H4

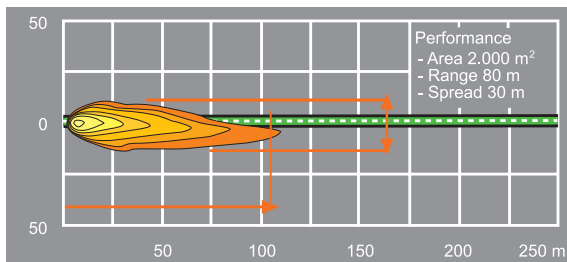

Performance H7

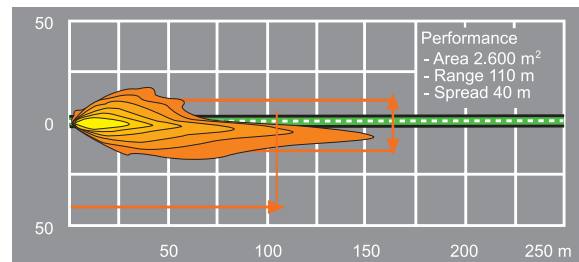

Negli anni '80 viene invece sviluppata una nuova tecnologia di rifrazione della luce applicabile ai proiettori alogeni (e successivamente a quelli Xenon). Si tratta della **tecnologia PES** (Poly-Ellipsoid-System). Questa tecnologia prevede l'utilizzo di una lente supplementare all'interno del proiettore che permette di incrementare la capacità illuminante (distribuzione della luce e intensità) a parità di dimensioni del proiettore.

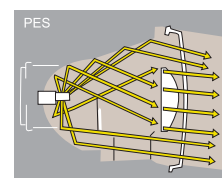
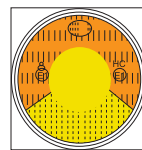
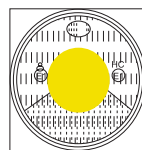
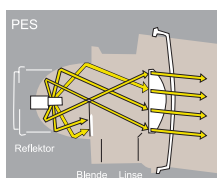

Negli anni '90 nasce invece il sistema Xenon, basato sull'utilizzo all'interno dei proiettori di lampade a scarica di gas (conosciute con le sigle D1S, D2S, D1R, D2R).

Si tratta di lampade in grado di fornire fino al 200% di luce in più rispetto ad una lampada alogena con minore consumo di energia.

Performance H7

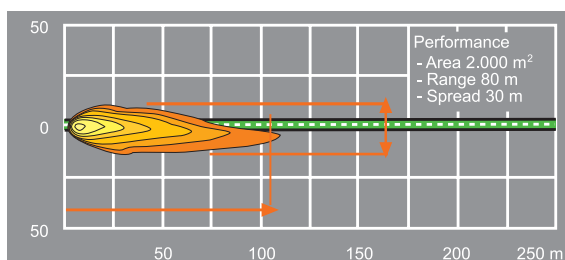

Performance Xenon

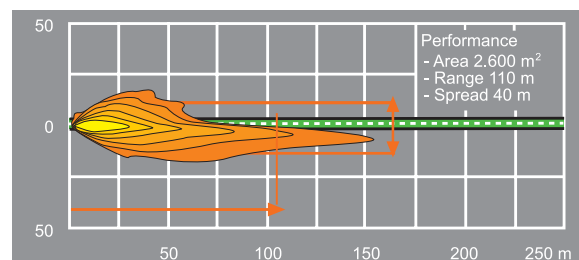

L'utilizzo di queste lampade richiede però l'applicazione di tecnologie molto sofisticate sui proiettori. Oltre ad un'ottica sempre più perfetta sono necessarie centraline elettroniche (ECU) in grado di produrre scariche di corrente a 10.000/20.000 Volt per l'accensione delle lampade, stabilizzatori di tensione e correttori di assetto automatici (indispensabili per non abbagliare gli altri veicoli) e sistemi elettrici lavafari (obbligatori per le omologazioni europee). Il sistema **Bi-Xenon** è l'ulteriore evoluzione di questa tecnologia e consiste nell'utilizzo di un attuatore elettromeccanico in grado di spostare la posizione della lampada in pochi centesimi di secondo modificandone la rifrazione all'interno del proiettore e riproducendo così sia il fascio anabbagliante che quello abbagliante per mezzo di una sola lampada.

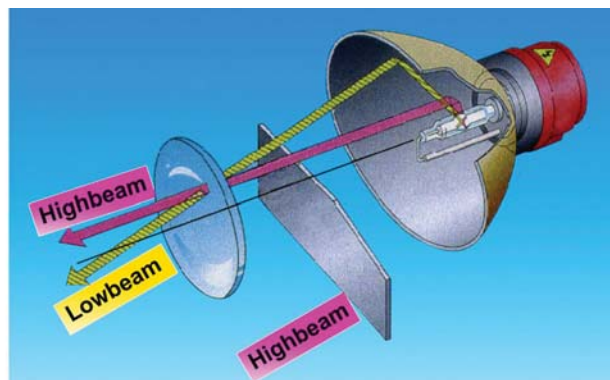
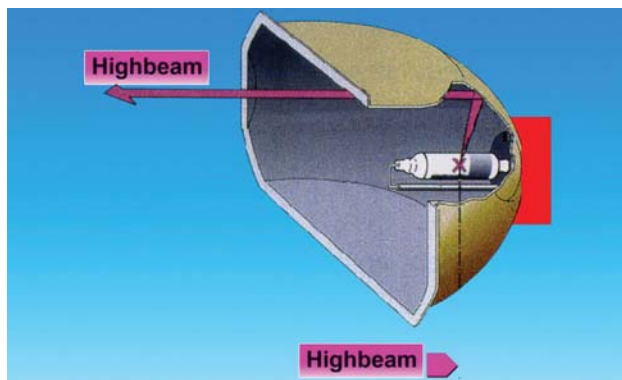

Le tecnologie più recenti hanno sviluppato i sistemi **SFS (Static Frontlighting Systems)** e **AFS (Adaptive Frontlighting Systems)**, o più semplicemente "luci di curva".

Il sistema SFS (o anche Fog-Cornering combination) è quello più semplice e consiste nell'utilizzo di una lampada addizionale all'interno di un proiettore fendinebbia (con apposita ottica) che si accende con l'attivazione dell'indicatore di direzione aumentando così l'illuminazione nella direzione in cui il veicolo vuole svoltare.

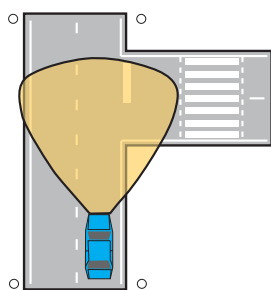

Situazione Normale

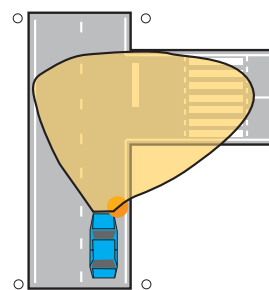

Accensione luce di curva statica abbinata ad indicatore di direzione

Molto più complesso invece è il sistema AFS (luce di curva dinamica).

Questo sistema è composto da una centralina elettronica in grado di elaborare i dati ricevuti da una serie di sensori (velocità del veicolo, raggio di sterzata, ecc.) e di trasmetterli a un correttore di assetto automatico che modifica l'angolazione verticale ed orizzontale del proiettore al fine di indirizzare il fascio luminoso verso le zone che necessitano di maggiore visibilità ai fini della sicurezza di guida.

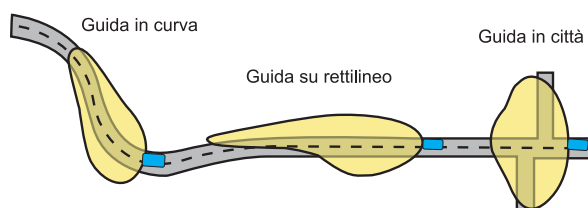

Infine, l'ultimo sviluppo tecnologico introdotto nella produzione di veicoli di serie e il **Sistema di Visione a Raggi Infrarossi (IR Vision System)**

Di derivazione militare, consiste nell'utilizzo all'interno del proiettore di un emettitore di raggi infrarossi che combinato ad una telecamera CCD permette la riproduzione su apposito display all'interno dell'abitacolo di una visione notturna prossima a quella che l'occhio umano ha in condizioni di luce diurna.



Active Night Vision System

CCD Camera
Display
Proiettore



Per quanto riguarda invece i Fanali Posteriori, le più importanti modifiche tecnologiche riguardano l'utilizzo dei **LED** invece delle normali lampadine.

L'utilizzo dei LED ha abbinato ai vantaggi di durata (oltre 10.000 ore) e di minor consumo energetico una vasta possibilità di innovazioni stilistiche.



Lancia Thesis



Peugeot 307 C.C.



VW Passat Limousine

One hundred years of development in the automotive lighting



Since the beginning of the last century enormous technological development have occurred for the automotive lighting, especially for head lamps and rear lights.

In 1912 the Italian company Carello has introduced as the first in Europe **electrical head lamps, powered by generators**. In the following phase head lamps with asymmetric light bulbs with two filaments have been developed in order to allow the function low and high beam at the same time.

In the beginning of the sixties the company Carello introduced the first head lamp with a new glow bulb type: **The halogen bulb**.

Regarding the previous technology (Bilux), the head lamp provides light with nearly the double intensity compared to a regular lamp.

The technical changes of the halogen bulb have increased the ability of head lamps to generate light. For example the usage of H7 halogen bulbs achieves a better light exploitation, which leads to an increase of about 30% more light than the H4 bulb.

Performance H4

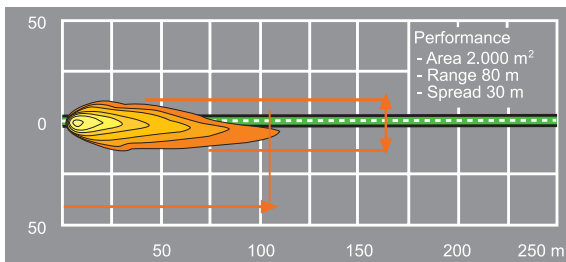

Performance H7

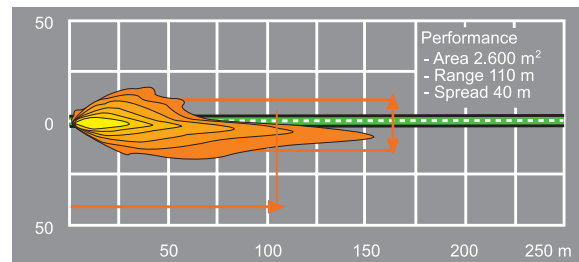

In the eighties on the other hand a new technology to fracture the light for halogen head lamps (and later for Xenon) has been developed: The **PES Technology (Poly-Ellipsoid-System)**.

This technology uses an additional lens inside the head lamp. This allows a higher light exploitation (through distribution and concentration) in relation with the head lamp size.

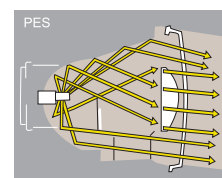
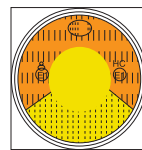
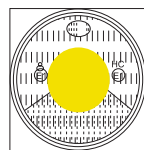
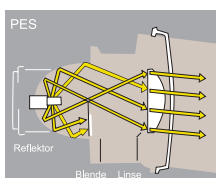

In the nineties the Xenon-System was born, based on the usage of gas discharge lamps (also known as D1S, D2S, D1R, D2R). These bulbs are able to provide up to 200% more light, using less energy than regular halogen bulbs.

Performance H7

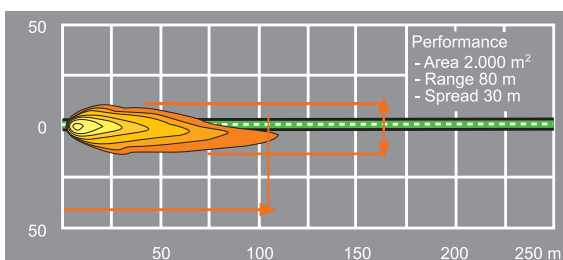

Performance Xenon

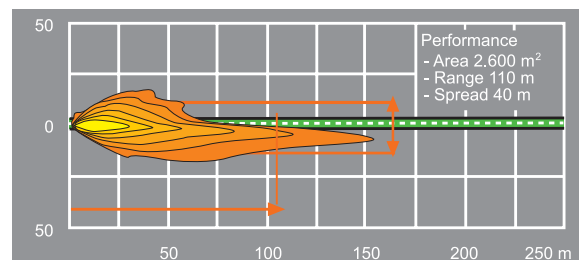

The usage of these bulbs requires a high demanding head lamp technology. Not only a more sophisticated optic, but also the usage of electronic ignition units (ECU) is required in order to achieve the necessary voltage of 10.000/20.000 to ignite the bulbs. Additionally, a constant tension regulator, an automatic load leveling (to avoid dazzling) and a head lamp washing system (required by law in Europe) are needed.

The **Bi-Xenon System** is the current development of this technology and is operating with an electromechanical adjustment of the bulb position within a fraction of a second. Therewith the light distribution for low and high beam is controlled with only one bulb.

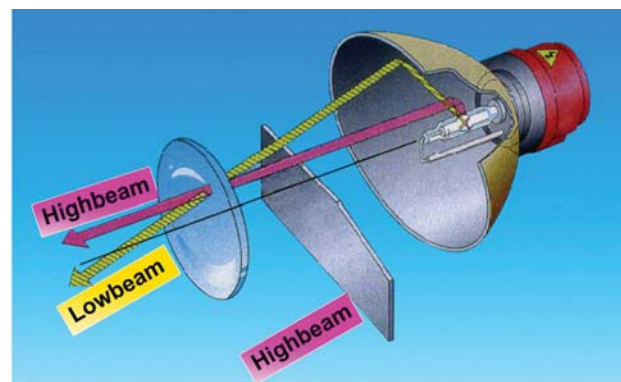
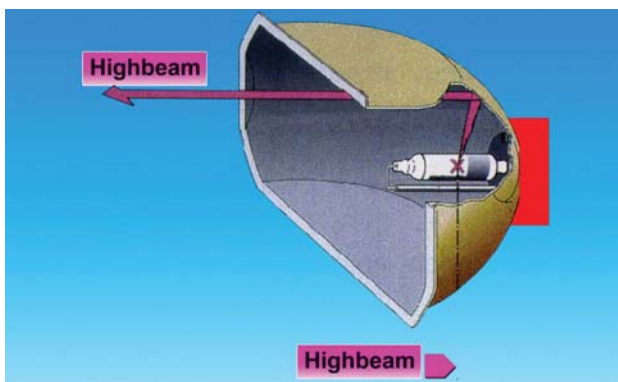

The latest development has heard the **Systems SFS (Static Front lighting System)** und **AFS (Adaptive Front lighting System)**, better known as curve light.

The System AFS (also fog - curve combination, static curve light) is the easier version and works with the usage of an additional bulb inside the fog lamp. The light ignites automatically when switching the indicator on and increases the lighting of the desired side.

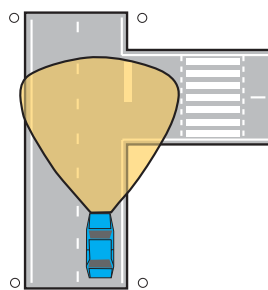

Normal

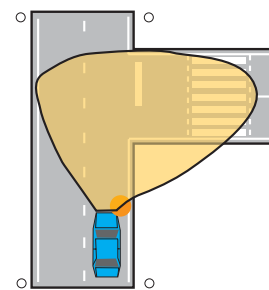

Activation of static curve light in combination with indicator.

Much more complex is the System AFS (dynamic curve light).

This system contains an electrical control unit which is able to process the data's (speed, steering angle, etc.) coming from various sensors in order to steer the automatic light regulation as well in horizontal as in vertical direction.

The better illumination of the important sections leads to a higher driving safety.

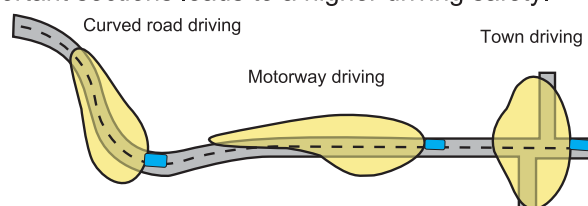

The most recent development has been introduced with the production of cars with **IR Night Vision System (Infrared supported night assistant)**.

This comes from the military section and works with in head lamps integrated infra red senders. The reflected infra red rays are converted by an electronic CDD camera to a picture and displayed on a screen inside the car: The night view is made visible like day light to the human eye.



CCD Camera
Display
Lamp



The most important development regarding rear lights has been achieved with the usage of **LED (Light Emitting Diode) Technology**. This introduction allowed, next to a much greater life time (over 10.000 hours) and lower energy consumption, with the smaller size new design possibilities.



Lancia Thesis



Peugeot 307 C.C.



VW Passat Limousine

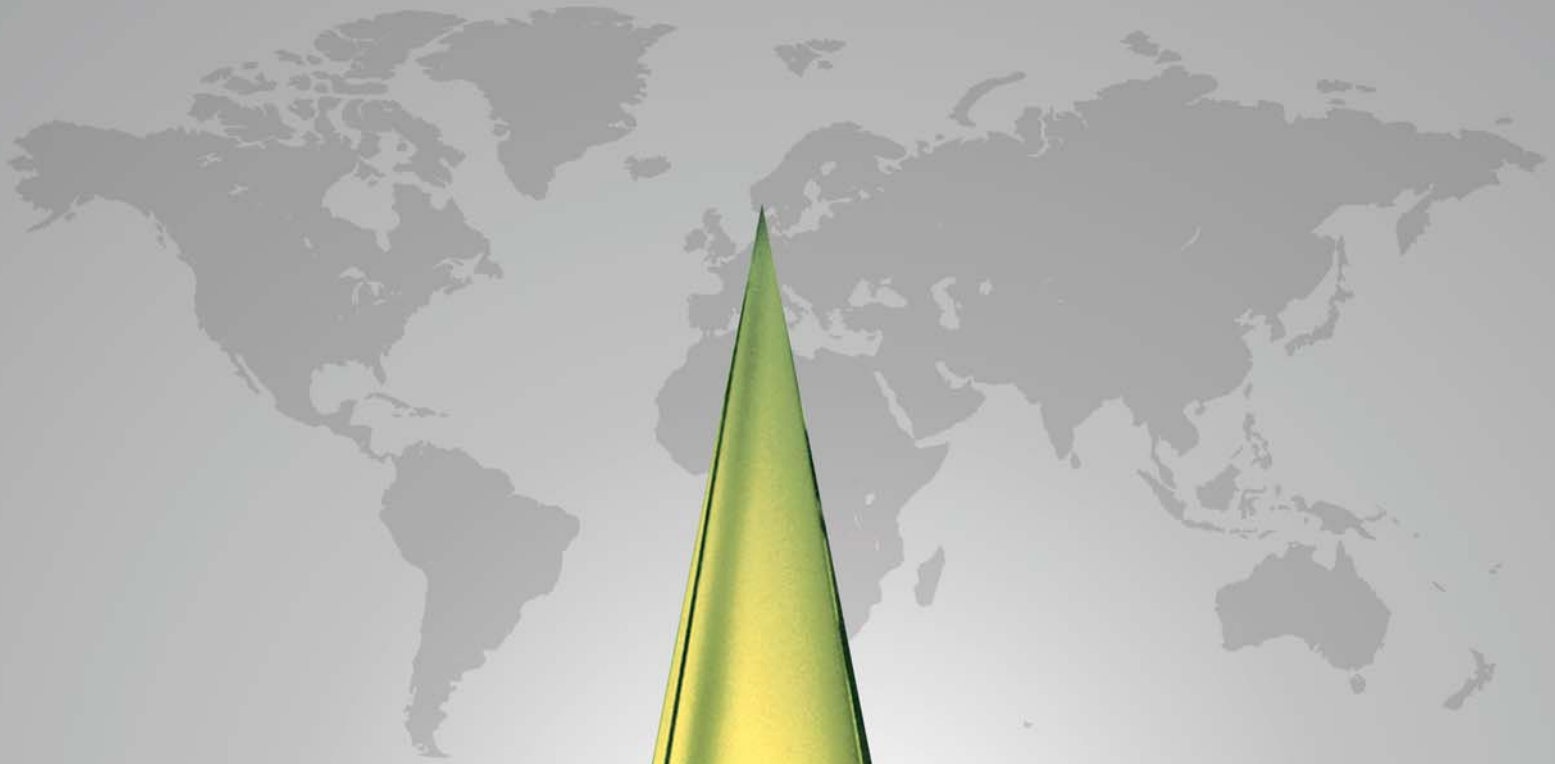

Ford Motor Company

2002 GOLD WORLD EXCELLENCE AWARD
MAKO ELEKTRİK SANAYİ VE TİCARET A.Ş.
HEADLAMPS & WIPER SYSTEMS
QUALITY, COST & DELIVERY

2002 GOLD WORLD EXCELLENCE AWARD
MAKO ELEKTRİK SANAYİ VE TİCARET A.Ş.
HEADLAMPS & WIPER SYSTEMS
QUALITY, COST & DELIVERY

MAKO's Total Quality Management Approach Milestones

- 1970 Company establishment;
- 1972 Production activities start-up; The first waste water treatment plant was built;
- 1984 Quality circles were established;
- 1992 The first Quality Manual is published according to Ford Q1 Manual;
- 1993 GM, AGM and the Factory Manager attended TQM training course at Isvor - FIAT, Italy; Mako - Koç 2000 Committee was established; Improvement Project Team activities were initiated; The initial Quality Policy was set; The Quality Assurance System was established; The first Self-Assessment is realized according to Malcolm Baldrige Model; The Lighting and air conditioning plants were opened;
- 1993 The waste water treatment plant was modernized and its capacity increased; Natural gas usage for heating introduced; 1994 MAKO Koç 2000 Committee was expanded, the second self-assessment was made according to EFQM Model and Koç 2000 Policy and Strategy Development and Application Model was prepared; The Company was assessed as A Class manufacturer by Oyak Renault according to EAQF Quality System Assessment; Self- Assessment was done according to ISO 9002 and the quality manual was published according to ISO 9000;
- 1995 The first Mako Quality Meeting was held; The Company was entitled for ISO 9002 the Quality Assurance System Certificates by the TSE and BVQI; The Lean Production System Master Plan was prepared; Flow Value analysis activities and the new Layout were done; The process analysis and the Lean Production organization model was defined; Kanban and SMED Pilot applications were made; Personnel Suggestion System is established; The Company was assessed as the A Class manufacturer by Koç Automotive Group Quality System Supervisors; The first Organizational Climate Survey was administered;
- 1996 The Lean Production technologies and systems were designed and introduced; The Personal Suggestion System was revised;
- 1996 Pilot TPM activities were started; Layout transformed into linear pipeline model; The production units started their activities; Mako applied first time for TÜSIAD Kal-Der National Quality Award; The Indicators System is set; The first Successful Supplier or the year Award was granted; Natural gas utilization is started; The first People's Satisfaction Survey was applied;
- 1997 The Company was assessed as A-Class manufacturer by ANFIA according to the AVSQ 94 Quality System Supervision; Entitlement for ISO Environment Incentive Prize; Application to TÜSIAD Kal-Der National Quality Award
- 1998 The first Lean Production Self-Assessment was effected; Kaizen activities were initiated; second time and remaining to field visit; Certification of Quality System according to ISO 9002 (BVQI, TSE); Foundation of Mako authorized services;
- 1999 First APQP and PPAP applications with Ford/V184 & V227 projects; Designing V227 Windshield Wiper; Realizing poly-carbonate lens production; First Full Service Supplier electromechanical projekt V227 windshield wiper sourced Mako Accomplishing to possess E.M.C. property in small motors;
- 2000 Improvement of Quality Assurance System according to ISO 9001/QS 9000 and obtaining QS9000 certification (BVQI); Classification of Mako as A-grade supplier by Oyak-Renault according to EAQF; Realization of Clean Room (Class: 100.000); Designing and production of small motors with -5dB vibration level.
- 2001 First project was started for Ford Europe (B256 stoplamp) Laboratories were approved by Fiat
- 2002 First product was delivered to Ford (B256 stoplamp) Q1 Activities were started
- 2003 2002 Gold "World Excellence Award" (Ford Motor Company) ISO / TS 16949 Quality Management Systems Certificated by BVQI. ISO 14001 Environmental Management Systems Certificated by BVQI. ISO 9001:2000 Quality Management Systems Certificated by TSE. First Full service supplier lighting project (V347) headlamp sourced Mako Fiat New Punto rear lighting program sourced to Mako, V347 Ford New Transit headlamp designed and developed successfully by Mako
- 2005 Koç Holding has transferred its share to Marelli and Mako became %95 Marelli Group.
- 2006 Fiat Ducato Stop Lamp production was started. Mako was nominated for BMW1 and 5 series fog lights. DC fog light business was sourced to Mako. Mako was nominated for Honda CRV Fog Light and Volvo Fog Light.
- 2007 First HID (Xenon) Head Lamp and LED Stop Lamp projects were acquired. Fiat Bravo Fog Light production was started. Fiat Linea Lamp and Rear Lamp production was started.



MAKO'nun TKY Yaklaşımındaki Kilometre Taşları

- 1970 MAKO'nun şirket olarak kuruluşu,
1972 MAKO'nun üretime başlaması, İlk Arıtma Tesisinin Açılması,
1984 Kalite Çemberlerinin kurulması,
1992 Ford Q1 kitapçığına göre ilk El Kitabının Yayını
1993 G.Gd., G.md.Yrd. ve Fb.Md.nün TKY Eğitimi için Isvor-FIAT'a gidişleri,
Mako Koç 2000 Komitesinin oluşturulması,
İPE Çalışmalarının başlatılması,
İlk Kalite Politikasının oluşturulması,
Kalite Güvence Sisteminin kuruluşu,
Malcolm Baldrige'a göre öz değerlendirilmenin yapılması,
Aydınlatma ve iklimlendirme tesislerinin açılışı,
1993 Arıtma tesisinin modernizasyonu ve Kapasite Arttırımı,
Isıtmada doğalgaz kullanımına geçiş,
1994 MAKO Koç 2000 Komitesinin genişletilmesi,
EFQM modeline göre ikinci öz değerlendirme,
Koç 2000 Politika ve Strateji geliştirme ve uygulama modelinin oluşturulması,
Oyak Renault EAQF Kalite Sistem Denetlemesinde A-Sınıfı imalatçı olarak değerlendirilme,
ISO 9002'ye göre iç denetim,
ISO 9000'e göre Kalite El Kitabı yayını,
1995 İlk MAKO Kalite Toplantısı'nın düzenlenmesi,
ISO 9002 Kalite Güvence Sistem Belgelerine hak kazanılma (TSE ve BVQI),
Yalın üretim projesi master planı yapılması,
1995 Akış değer analizi çalışmaları ve yeni LAYOUT tasarımının yapılması,
Süreç analizi çalışmaları ve yalın üretim organizasyon modelinin tanımlanması,
KARBAN ve SMED pilot bölge uygulamalarının yapılması,
Bireysel öneri sisteminin kurulması,
Koç grubu Otomotiv Şirketleri Kalite Sistem denetlemesinde A-Sınıfı imalatçı olarak değerlendirilme,
1996 İlk Örgüt İklimi Anketinin yapılması,
yalın üretim tekniklerinin ve sistemlerinin tasarımı ve devreye alınması,
Bireysel öneri sisteminin revizyonu
Pilot TPM çalışmasının başlatılması.
Layout'un doğrusallaştırılması,
1996 Üretim birimleri'nin göreve başlaması
TÜSİAD-KalDer Ulusal Kalite Ödülü İlk Başvurusunun yapılması,
Göstergeler sisteminin hazırlanması
İlk Başarılı Tedarikçi Ödülünün verilmesi,
Üretim proseslerinde doğalgaz kullanımına geçiş
İlk çalışma hayatını değerlendirme anketinin yapılması,
İlk müşteri bağlılığı anketi,
1997 ANFIA AVSQ 94 Kalite sistem Denetiminde A-Sınıfı İmalatçı olarak değerlendirilme,
ISO Çevre Teşvik Ödülünün kazanılması.
İlk Yalın Üretim İç Denetimi'nin yapılması,
KAIZEN çalışmalarının başlatılması
1998 TÜSİAD-KalDer Ulusal Kalite ödülüne ikinci kez başvurulması ve saha ziyaretine kalınması,
Kalite Sisteminin ISO 9002'ye göre yeniden belgelendirilmesi (BVQI, TSE),
MAKO Yetkili Servisi İstasyonlarının kurulması,
1999 Ford V184/V227 projeleri ile birlikte ilk APQP ve PPAP uygulamaları,
İlk elektromekanik FSS projesi olan V227 Cam Silecek Motoru MAKO'ya verildi.
Polycarbonate lens üretiminin başlatılması,
E.M.C. özellikli küçük motorların üretilmeye başlanması,
2000 Kalite Güvence Sistemi'nin ISO 9001/QS 9000'e göre geliştirilmesi ve QS 9000 belgesinin alınması (BVQI),
Oyak Renault'un EAQF standardına göre yapmış olduğu denetimde MAKO'yu A-Sınıfı tedarikçi olarak değerlendirmesi,
Temizlik Sınıfı class: 100.000 olan Clean Room'un devreye alınması,
Vibrasyon seviyesi-5dB'in altında olan küçük motorların tasarlanması ve üretilmesi.
2001 Ford Avrupa ile ilk proje başlandı (B256 stop lambası)
Laboratuvar çalışmalarımız Fiat tarafından onaylandı
2002 Ford için ilk üretim teslimi yapıldı (B256 stop lambası)
Q1 aktivitelere başlandı.
2003 Ford Motor Company'nin her sene işbirliği yaptığı firmalar arasında,
"Kalite", "Fiyat" ve "Sevkiyat" alanında üstün performans gösteren şirketlere verdiği 2002 Altın "Dünya Mükemmellik Ödülü" sahibi.
İlk aydınlatma FSS projesi olan V347 far MAKO'ya verildi.
2004 Fiat yeni Punto stop lambası programı MAKO'ya verildi
V347 Ford yeni Transit far ürün geliştirme ve tasarımı başarıyla MAKO tarafından gerçekleştirildi.
ISO / TS 16949 Kalite Yönetim Sistemi Sertifikası BVQI tarafından verildi.
ISO 14001 Çevre Yönetim Sistemi Sertifikası BVQI tarafından verildi.
ISO 9001:2000 Kalite Yönetim Sistemi Sertifikası TSE tarafından verildi.
%95 Marel Holding oldu. Koç Grubu hisselerini devretti.
2005 Ducato stop lambası üretimi başladı.
2006 BMW 1 ve 5 serisi sis lambası projeleri MAKO'ya verildi.
Mercedes sis lambası projesi MAKO'ya verildi.
Honda CRV sis lambası projesi MAKO'ya verildi.
Volvo sis lambası projeleri MAKO'ya verildi.
2007 İlk HID (Xeno) far ve ledli stop projesi alındı.
Fiat Bravo sis lambası üretimi başladı.
Fiat Linea far ve stop lambası üretimi başladı.



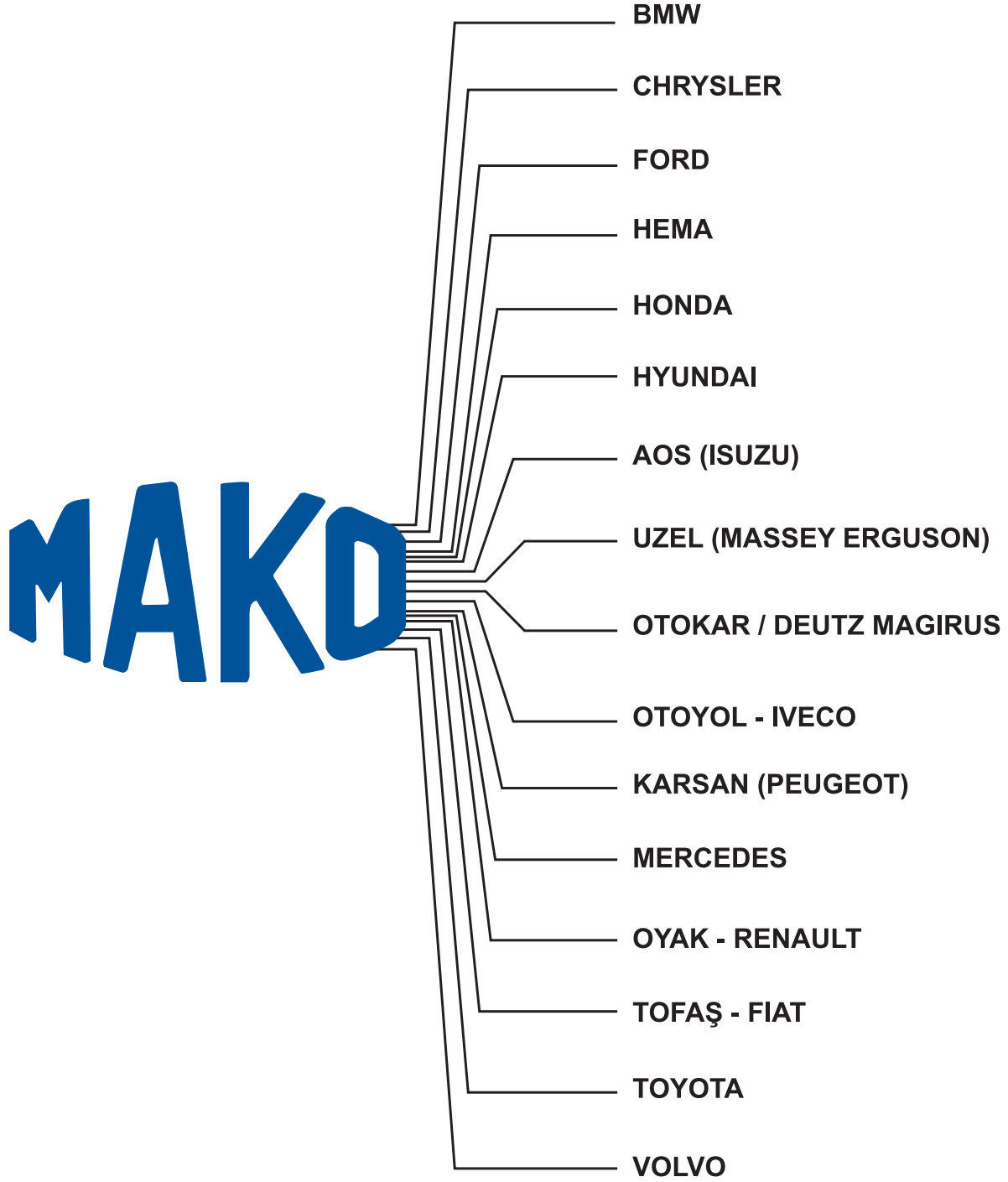

Açıklamalar
Legenda
Legend

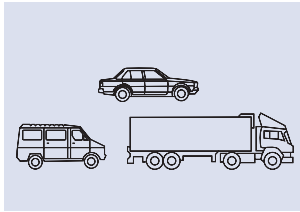

İmalat ve Model
Costruttore e modello
Make and model
Hersteller und Modell
Constructeur et modèle
Constructor y modelo
Montadora e modelo

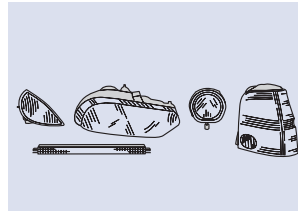

Ürün Tanıtımı
Descrizione prodotto
Product description
Produktbeschreibung
Description du produit
Descripción del producto
Descrição do produto

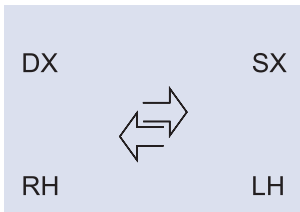

Sağ / Sol
Destro / Sinistro
Right / Left
Rechts / Links
Droit / Gauche
Derecho / Izquierdo
Direito / Esquerdo

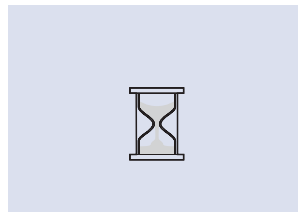

Üretim Yılı
Anno di produzione
Manufacturing year
Baujahr
Date de fabrication
Año de fabricación
Ano de fabricação

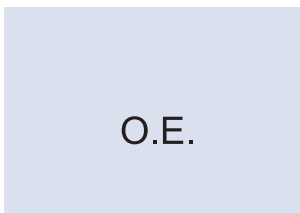

O. E. Referansı
Codice costruttore
O.E. Reference
Herstellernummer
Référence origine
Código constructor
Código montadora

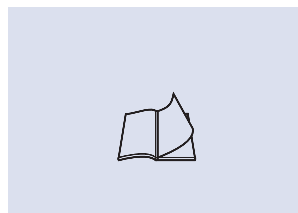

Sayfa
Página
Page
Seite
Page
Página
Página

Simgeler
Descrizione icone
Icons Description

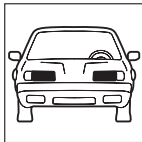

FAR
PROIETTORE PRINCIPALE
HEADLAMP
HAUPTSCHWEINWERFER
PROJECTEUR PRINCIPAL
PROJECTOR PRINCIPAL
FAROL PRINCIPAL

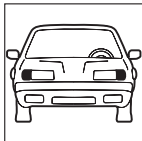

ÖN SINYAL
FANALE ANTERIORE
FRONT FLASHER
BLINKLEUCHTEN
CLIGNOTANT AVANT
PILOTO ANTERIOR
LANTERNA DIANTEIRA

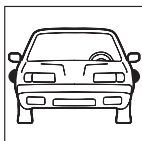

YAN SINYAL
FANALE LATERALE
SIDE LAMP
SEITENLEUCHTEN
CLIGNOTANT LATERAL
PILOTO LATERAL
LANTERNA LATERAL

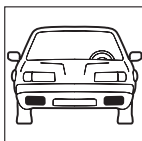

SIS LAMBASI
PROIETTORE AUSILIARIO
AUXILIARY LAMP
ZUSATZSCHWEINWERFER
PROJECTEUR AUXILIAIRE
PROJECTOR AUXILIAR
FAROL AUXILIAR

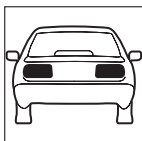

STOP LAMBASI
FANALE POSTERIORE
REAR LAMP
RÜCKLEUCHTEN
FEU ARRIERE
PILOTO POSTERIOR
LANTERNA TRASEIRA

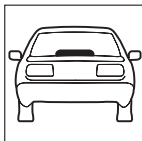

3. STOP
FANALE 3° STOP
3rd STOP LAMP
3. BREMSLEUCHTE
3e FEU STOP
PILOTO 3° STOP
LANTERNA 3° STOP

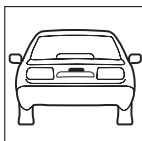

PLAKA LAMBASI
FANALE TARGA
NUMBER PLATE LAMP
KENNZEICHENLEUCHTE
ECLAIREUR DE PLAQUE
LUZ MATRICULA
LANTERNA MATRICULA

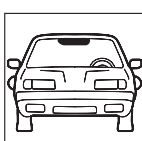

İÇ LAMBALAR
PLAFONIERA
INTERIOR LAMP
INNENLEUCHTE
PLAFONNIER
PLAFON INTERIOR
LANTERNA INTERNA

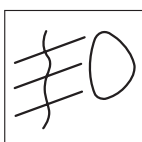

SIS LAMBASI
LUCE FENDINEBBIA
FOG LIGHT
NEBELSCHWEINWERFER
ANTIBROUILLARD
LUZ ANTINEBLA
LUZ DE NEBLINA



ÇERÇEVE RENGİ
COLORE CORNICE
FRAME COLOUR
RAHMENFARBE
COULEUR ENCADREMENT
COR DA MOLDURA
COR DA MOLDURA

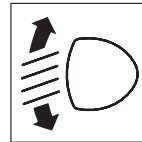

FAR AYAR MOTORU
CORRETTORE ASSETTO
LOAD LEVEL
STELLMOTOR FÜR LWR
CORRECTEUR D'ASSIETTE
CORRECTOR DE ALTURA
CORRETOR DE ALTURA

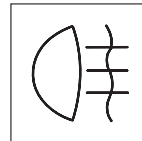

ARKA SIS LAMBASI
RETRONEBBIA
REAR FOG LIGHT
NEBELSCHLUSSLEUCHTE
ANTIBROUILLARD ARRIERE
LUZ POSTERIOR ANTINEBLA
LUZ TRASEIRA DE NEBLINA

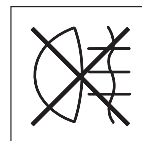

ARKA SIS LAMBASIZ
SENZA RETRONEBBIA
WITHOUT REAR FOG LIGHT
OHNE NEBELSCHLUSSLEUCHTE
SANS ANTIBROUILLARD ARRIERE
SIN LUZ POSTERIOR ANTINEBLA
SEM LUZ TRASEIRA DE NEBLINA

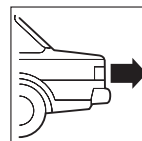

GERI VİTES LAMBASI
RETROMARCIA
BACKUP LIGHT
RÜCKFAHERLEUCHTE
FEU DE RECVL
LUZ DE MARCHA ATRAS
LUZ DE MARCHA RÉ

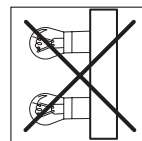

AMPUL TAŞIYICISIZ
SENZA PORTALAMPADE
WITHOUT BULB HOLDER
OHNE LAMPENTRÄGER
SANS PORTE LAMPE
SIN PORTALAMPARAS
SEM PORTA-LÂMPADAS

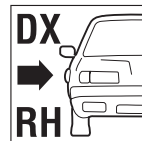

SAĞ TARAF
LATO DESTRO
RIGHT SIDE
RECHTE SEITE
CÔTE DROIT
LADO DERECHO
LADO DIREITO



SOL TARAF
LATO SINISTRO
LEFT SEITE
CÔTE GAUCHE
LADO IZQUIERDO
LADO ESQUERDO

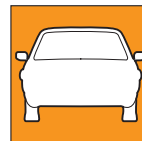

SARI CAM
LENTE ARANCIONE
AMBER LENS
GLAS, ORANGE
CABOCHON ORANGE
TULIPA AMBAR
LENTE ÂMBAR

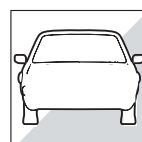

FÜME CAM
LENTE FUME
SMOKED LENS
RAUCHGLAS
CABOCHON FUME
TULIPA AHUMADA
LENTE FUMÉ

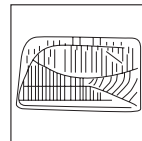

SADECE CAM
SOLO LENTE (ANTERIORE/POSTERIORE)
LENS (FRONT/REAR)
NUR GLAS (VORNE/HINTEN)
CABOCHO SEUL (AVANTI/ARRIERE)
SOLO TULIPA (DELANTERA/TRASERA)
SOMENTE LENTE (DIANTEIRA/TRASEIRA)

Araç Markalarına Göre Uygulamalar
Applicazione per marca e veicolo
Vehicle application guide

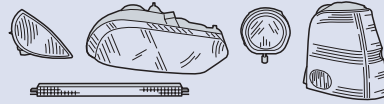
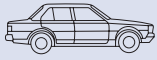

CODE

ALFA ROMEO 156 - 156 Sportwagon



10/97



H1

**No Braket
Braketsiz**

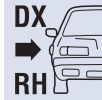

041070111000

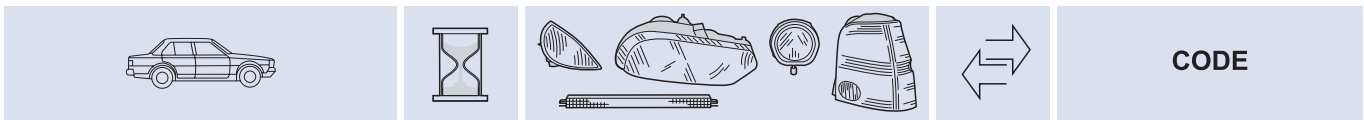

CODE

BMW Serie 5 (E60)

	<p>07 ↓</p>	<p>H8</p>	<p>DX → RH</p>	040150111000
			<p>SX ← LH</p>	040160111000

BMW Serie 1 (E87)

	<p>07 ↓</p>	<p>H11</p>	<p>DX → RH</p>	040170111000
			<p>SX ← LH</p>	040180111000

BMW Mini Cooper R56 Park Position Lamp.

	<p>07 ↓</p>	<p>W5W</p>	<p>DX → RH</p>	040015111100
--	-----------------	-------------------	------------------------	--------------

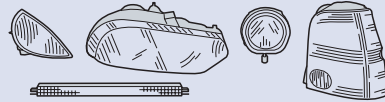
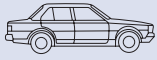

BMW Mini Cooper R56

	<p>07 ↓</p>	<p>H8</p>	<p>DX → RH</p>	040010111000
--	-----------------	------------------	------------------------	--------------









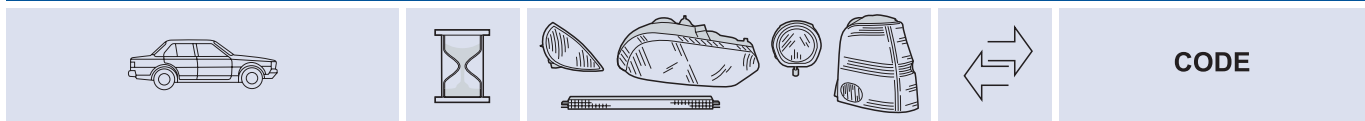

CODE

CHRYSLER (AS250)

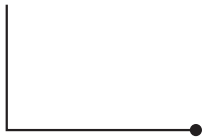

	<p>03 ↓</p>	 <p>H1 H4</p>	<p>DX → RH</p>	<p>010030111000</p>
			<p>← SX LH</p>	<p>010040111000</p>







CITROËN Nemo

	<p>07 ↓</p>	 H4	<p>DX RH</p> 	<p>045560111000</p>
			<p>SX LH</p> 	<p>045570111000</p>
	<p>07 ↓</p>	 H4 RHD	<p>DX RH</p> 	<p>045565111000</p>
			<p>SX LH</p> 	<p>045575111000</p>

CITROËN Nemo (Cargo)

	<p>07 ↓</p>	 H1	<p>DX RH</p> 	<p>040250111000</p>
			<p>SX LH</p> 	





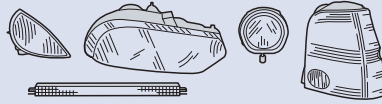
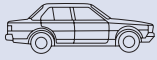







CITROËN Nemo (Combi)

	<p>07 ↓</p>	 H1	<p>DX RH</p> 	<p>040255111000</p>
			<p>SX LH</p> 	<p>040260111000</p>



CODE

CITROËN Jumper

	06 		DX  RH 	020150111000
			SX  LH 	020160111000
Trophic	06 		DX  RH 	020155111000
			SX  LH 	020165111000

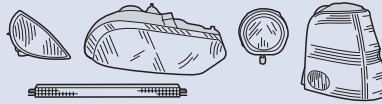
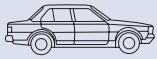

CODE

CITROËN Belingo



09/96



040325999000

CITROËN Evasion RY



01/99



040325999000

CITROËN Saxo

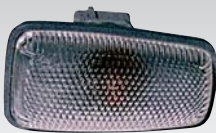

11/94



12/98



040325999000

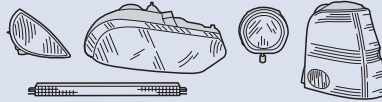
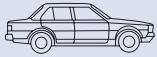

CODE

CITROËN Xantia RY



01/98

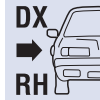
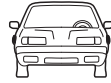

040325999000

CITROËN Xsara



09/97



08/00

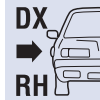

040325999000

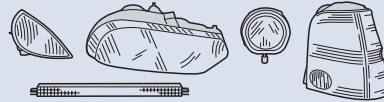
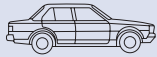

CODE





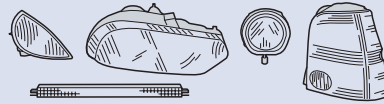
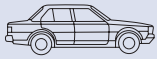

















FIAT - TOFAŞ Albea Sole

	<p>07</p> 	  <p>H1 H7</p>	<p>DX</p>  <p>RH</p>	042801111000
			<p>SX</p>  <p>LH</p>	042811111000
	<p>07</p> 	 	<p>DX</p>  <p>RH</p>	041525111000
			<p>SX</p>  <p>LH</p>	041535111000
	<p>07</p> 		<p>DX</p>  <p>RH</p>	041505111000
			<p>SX</p>  <p>LH</p>	041515111000
	<p>07</p> 	  <p>H1</p>	<p>DX</p>  <p>RH</p>	041070111000
			<p>SX</p>  <p>LH</p>	



CODE





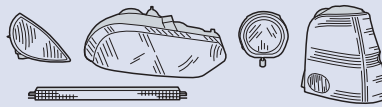
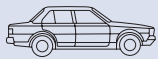























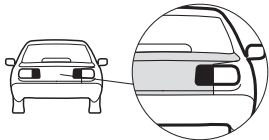









FIAT - TOFAŞ Palio Sole

	<p>07</p> 	  <p>H1 H7</p>	<p>DX</p>   <p>RH</p>	042801111000
			<p>SX</p>   <p>LH</p>	042811111000
	<p>07</p> 		<p>DX</p>   <p>RH</p>	041760111000
			<p>SX</p>   <p>LH</p>	041770111000
	<p>07</p> 	  <p>H1</p>	<p>DX</p>   <p>RH</p>	041070111000
			<p>SX</p>   <p>LH</p>	



CODE





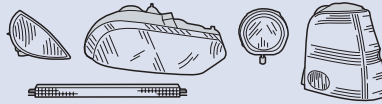

























FIAT - TOFAŞ Albea (172)

	02  05	  H1 H7	DX  RH 	043020111000
			SX  LH 	043030111000
	02  05	  H1 H7	DX  RH 	043026111000
			SX  LH 	043036111000
	02  05	 	DX  RH 	041520111000
			SX  LH 	041530111000
	02  05		DX  RH 	41500111000
			SX  LH 	41510111000
	02  05	  H1	DX  RH 	041070111000
			SX  LH 	



CODE

FIAT - TOFAŞ Palio (171)

	02  05	  H1 H7	DX  RH 	043020111000
			SX  LH 	043030111000
	02  05	  H1 H7	DX  RH 	043026111000
			SX  LH 	043036111000
	02  05		DX  RH 	041760111000
			SX  LH 	041770111000
	02 	  H1	DX  RH 	041070111000
			SX  LH 	

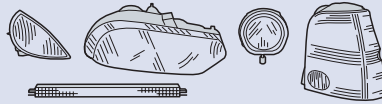
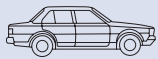

CODE

FIAT Brava





	<p>01/95 ↓</p>	<p>H1</p>	<p>DX → RH</p> <p>SX ← LH</p>	<p>041070111000</p>
--	--------------------	------------------	---	---------------------

FIAT Bravo (198)



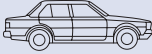

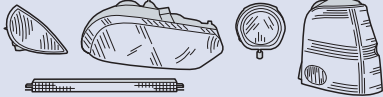









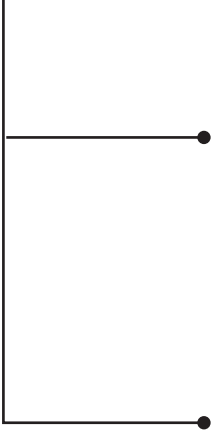













	<p>07 ↓</p>	<p>H11</p>	<p>DX → RH</p> <p>SX ← LH</p>	<p>045380111000</p> <hr/> <p>045390111000</p>
--	-----------------	-------------------	---	---





FIAT Bravo

	<p>01/95 ↓</p>	<p>H1</p>	<p>DX → RH</p> <p>SX ← LH</p>	<p>041070111000</p>
--	--------------------	------------------	---	---------------------



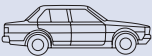

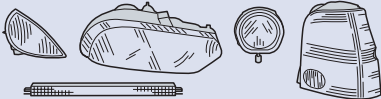





























				CODE
---	---	--	---	-------------

FIAT - TOFAŞ Doblo

	00 ⇓ 05	 H1 H7 	DX → RH 	040540111000
			SX ← LH 	040550111000
	00 ⇓ 05	 H1 H7 	DX → RH 	040545111000
			SX ← LH 	040555111000
	00 ⇓ 05	 H1 H7 (RHD) 	DX → RH 	040542111000
			SX ← LH 	040552111000
	00 ⇓ 05	 	DX → RH 	040600111000
			SX ← LH 	040610111000
	00 ⇓ 05	 (RHD) 	DX → RH 	040601111000
			SX ← LH 	040611111000
	00 ⇓ 05	 CENTR	DX → RH 	040580111000
			SX ← LH 	

				CODE
---	---	--	---	-------------

FIAT - TOFAŞ Doblo Malibu

	00 ⇓ 05	 H1 H7		DX   RH	040543111000
				  SX LH	040553111000
	00 ⇓ 05	 H1 H7 (RHD)		DX   RH	040541111000
				  SX LH	040551111000
	00 ⇓ 05	 		DX   RH	040600111000
				  SX LH	040610111000
	00 ⇓ 05	 (RHD)		DX   RH	040601111000
				  SX LH	040611111000
	00 ⇓ 05	 CENTR		DX   RH	040580111000
				  SX LH	

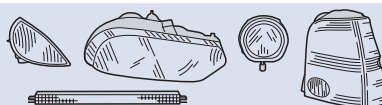
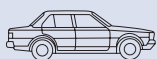

CODE





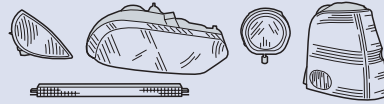
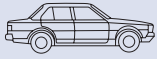

FIAT - TOFAŞ Doblo Restyling

	<p>06 ⇓</p>	  <p>H1 H7</p>	<p>DX → RH</p> 	043680111000
			<p>SX ← LH</p> 	043690111000
	<p>06 ⇓</p>	 <p>H1 H7</p>	<p>DX → RH</p> 	043685111000
			<p>SX ← LH</p> 	043695111000
	<p>06 ⇓</p>		<p>DX → RH</p> 	020110111000
			<p>SX ← LH</p> 	020120111000
	<p>06 ⇓</p>	  <p>H1</p>	<p>DX → RH</p> 	041070111000
<p>SX ← LH</p> 				
	<p>06 ⇓</p>	 <p>CENTR</p>	<p>DX → RH</p> 	040580111000
<p>SX ← LH</p> 				



CODE





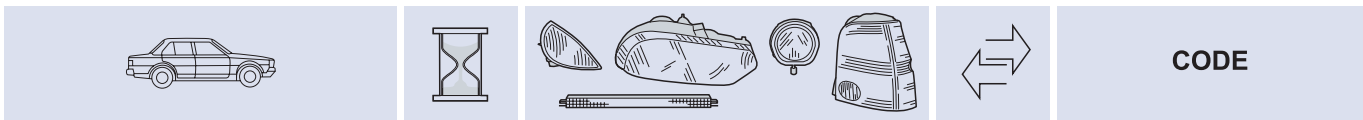





FIAT Ducato (250)

	<p>06 ⇓</p>		<p>DX ➔ RH</p> 	<p>020150111000</p>
			<p>SX ← LH</p> 	<p>020160111000</p>
<p>Trophic</p>	<p>06 ⇓</p>		<p>DX ➔ RH</p> 	<p>020155111000</p>
			<p>SX ← LH</p> 	<p>020165111000</p>







CODE





FIAT Fiorino (MCV 225 FL)

	07 ↓	 H4		DX  RH	045560111000
			 SX LH	045570111000	
	07 ↓	 H4 RHD		DX  RH	045565111000
			 SX LH	045575111000	

FIAT Fiorino (Cargo)

	07 ↓	 H1		DX  RH	040250111000
				 SX LH	

FIAT Fiorino (Combi)



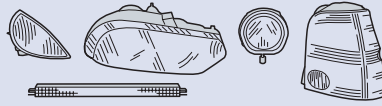
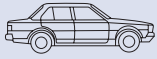

	07 ↓	 H1		DX  RH	040255111000
				 SX LH	040260111000

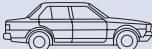

CODE

FIAT Grande Punto (199)

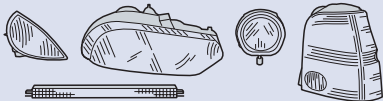
	06 		DX RH	020130111000
			SX LH	020140111000
	06 	 	DX RH	020135111000
	06 	 	SX LH	020145111000
	06 	 RHD	DX RH	020136111000
	06 	 RHD	SX LH	020146111000

				CODE
---	---	--	---	-------------

FIAT - TOFAŞ Linea (D200)

	07 ⇓	 H1 H7	 DX RH	045220111000
			 SX LH	045230111000
	07 ⇓	 H1 H7	 DX RH	045225111000
			 SX LH	045235111000
	07 ⇓		 DX RH	020190111000
			 SX LH	020200111000
	07 ⇓	 	 DX RH	020195111000
			 SX LH	020205111000
	07 ⇓	 H1	 DX RH	041070111000
			 SX LH	

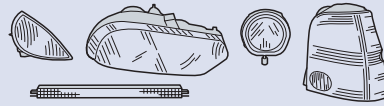
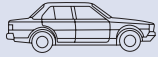

CODE

FIAT Marea



10/96



H1

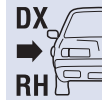

041070111000

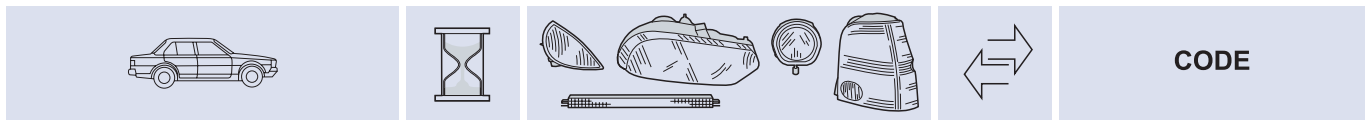

FIAT - TOFAŞ Palio / Siena / Weekend (178)

	98 ⇓ 02	 H3 H7	DX   RH	038540111000
			 SX  LH	038550111000
	98 ⇓ 02	 H3 H7	DX   RH	038541111000
			 SX  LH	038551111000
	98 ⇓ 02		DX   RH	038561111000
			 SX  LH	038571111000
	98 ⇓ 02	 H3	DX   RH	040020111000
			 SX  LH	040030111000
	98 ⇓ 02		DX   RH	038561111000
			 SX  LH	038571111000
	98 ⇓ 02		DX   RH	040095111000
			 SX  LH	

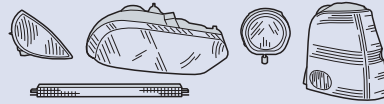
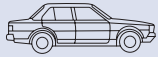

CODE

FIAT - TOFAŞ Palio (178)

	<p>98 ⇓ 02</p>		<p>DX → RH</p>	038640111000
			<p>SX ← LH</p>	038650111000

FIAT - TOFAŞ Siena (178)

	<p>98 ⇓ 02</p>		<p>DX → RH</p>	038620111000
			<p>SX ← LH</p>	038630111000

FIAT - TOFAŞ Palio Weekend (178)

	<p>98 ⇓ 02</p>		<p>DX → RH</p>	038600111000
			<p>SX ← LH</p>	038610111000

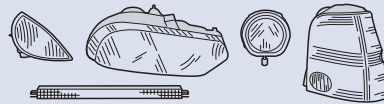
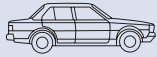

CODE



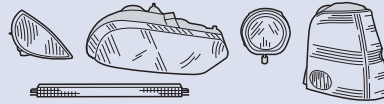
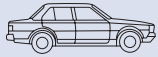

FIAT - TOFAŞ Palio / Siena / Weekend (178) Ibrida

	98 ⇓ 02	 H3 H7		DX → RH	04192111000
				SX ← LH	04193111000
	98 ⇓ 02	 H4		DX → RH	04192011000
				SX ← LH	04193011000
	98 ⇓ 02			DX → RH	04204011000
				SX ← LH	04205011000
	98 ⇓ 02	 H3		DX → RH	04002011000
				SX ← LH	04003011000
	98 ⇓ 02			DX → RH	03856111000
				SX ← LH	03857111000
	98 ⇓ 02			DX → RH	04009511000
				SX ← LH	





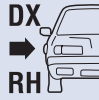

CODE

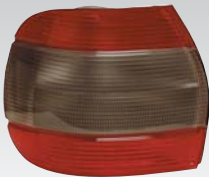

FIAT - TOFAŞ Palio (178) Ibrida

	<p>98 ⇓ 02</p>		<p>DX → RH</p> 	038640111000
			<p>SX ← LH</p> 	038650111000

FIAT - TOFAŞ Siena (178) Ibrida

	<p>98 ⇓ 02</p>		<p>DX → RH</p> 	038620111000
			<p>SX ← LH</p> 	038630111000

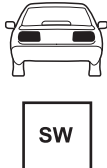
FIAT - TOFAŞ Palio Weekend (178) Ibrida



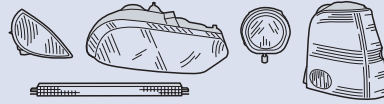
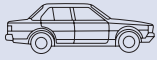

	<p>98 ⇓ 02</p>		<p>DX → RH</p> 	038600111000
			<p>SX ← LH</p> 	038610111000

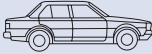

CODE

FIAT - TOFAŞ Şahin / Doğan / Kartal (131)

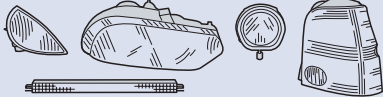
	95 02	 H4	DX RH	032710211000
			SX LH	032720211000
	95 02		DX RH	32830111000
			SX LH	32840111000
	95 02	 	DX RH	32811111000
			SX LH	32821111000
	95 02	 H1		032600722000

				CODE
---	---	--	---	-------------

FIAT - TOFAŞ Tempra

	90 ⇓ 98	 H4	 DX RH	033130211000
			 SX LH	033140211000
	90 ⇓ 98	 H4	 DX RH	033130212000
			 SX LH	033140212000
	90 ⇓ 98	 H4	 DX RH	033150211000
			 SX LH	033160211000
	90 ⇓ 98	  H3	 DX RH	033700111000
			 SX LH	033710111000
	90 ⇓ 98	 	 DX RH	033900211000
			 SX LH	033910211000
	90 ⇓ 98	  	 DX RH	016910964900
			 SX LH	016911964900

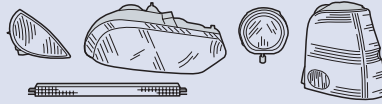
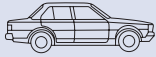

CODE

FIAT - TOFAŞ Tipo / Tipo Maquillage

	90 98	 H4	DX RH 	036880111000
			SX LH 	036890111000
	90 98		DX RH 	036340111000
			SX LH 	036350111000
	90 98	 H3	DX RH 	036840111000
			SX LH 	036850111000
	90 98		DX RH 	033210211000
			SX LH 	033220211000

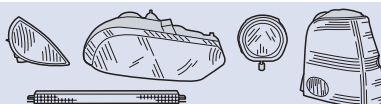
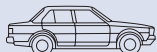

CODE

FIAT - TOFAŞ Uno / Uno Restyling

	89 01	 H4	DX RH 	03344111000
			SX LH 	03345111000
	89 01	 H4	DX RH 	033441112000
			SX LH 	033451112000
	89 01	 R2	DX RH 	033441211000
			SX LH 	033451211000
	89 01	 R2	DX RH 	033441113000
			SX LH 	033451113000
	89 01		DX RH 	033481111000
			SX LH 	033491111000
	89 01		DX RH 	033940111000
			SX LH 	033950111000

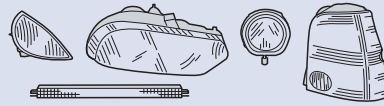
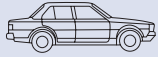

CODE





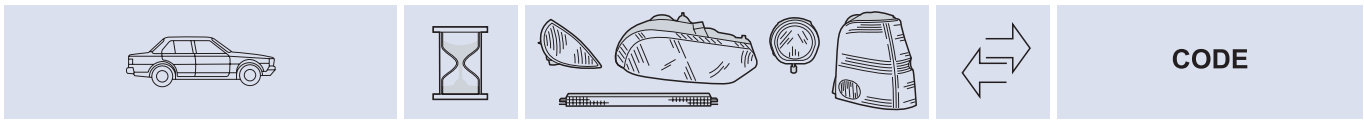







FIAT - TOFAŞ Uno / Uno Restyling

	<p>90 ↓ 01</p>		<p>DX → RH</p>	<p>016830111000</p>
			<p>SX ← LH</p>	<p>016831111000</p>











CODE

FORD Transit (V83)

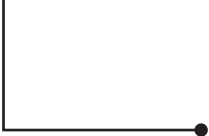
	94 ⇓ 01	 H4	DX → RH 	054530111000
			 SX ← LH	054531111000
	94 ⇓ 01	 H4 (RHD)	DX → RH 	054535834000
			 SX ← LH	054536834000
	94 ⇓ 01		DX → RH 	054595551111
			 SX ← LH	054595552111



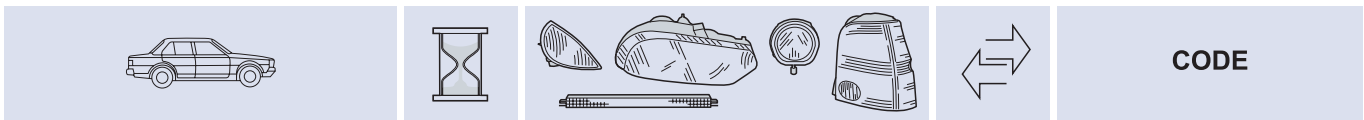

FORD Transit (V184)

	01 ⇓ 06	 H4 	DX → RH 	038039111000
			 SX ← LH	038040111000
	01 ⇓ 06	 H4	DX → RH 	038139111000
			 SX ← LH	038140111000

















CODE

FORD Transit (V184)

	01 ⇓ 06		DX → RH 	038404111000
			 SX ← LH	038405111000

FORD Transit (V347) / New Transit

	06 ⇓	 H4		DX → RH 	010090111000
			 SX ← LH	010100111000	
●	06 ⇓	 H4		DX → RH 	010095111000
			 SX ← LH	010105111000	
●	06 ⇓	 H4 (RHD)		DX → RH 	010091111000
			 SX ← LH	010101111000	
●	06 ⇓	 H4 (RHD)		DX → RH 	010096111000
			 SX ← LH	010106111000	

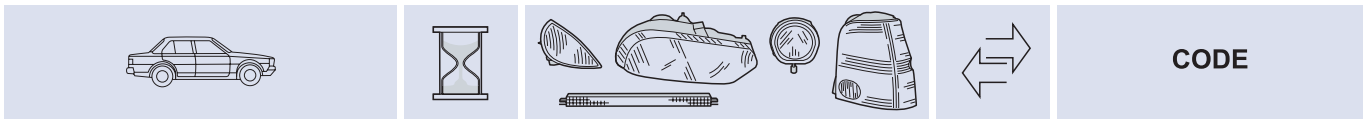

CODE

FORD Transit (V347) / New Transit

	06 ↓		DX → RH	020035111000
			SX ← LH	020045111000





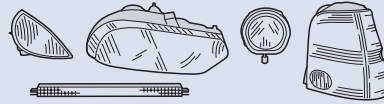
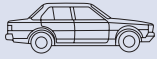



FORD Transit (V227) / Connect

	06 ↓	 H4	DX → RH	039130111000
			SX ← LH	039140111000
	06 ↓	 H4 (RHD)	DX → RH	039135111000
			SX ← LH	039145111000



CODE

FORD Fiesta (B256)

	<p>02 ⇓ 05</p>		<p>DX ➔ RH</p> 	<p>020010111000</p>
			<p>SX ← LH</p> 	<p>020025111000</p>
	<p>02 ⇓ 05</p>	 <p>(RHD)</p>	<p>DX ➔ RH</p> 	<p>020016111000</p>
			<p>SX ← LH</p> 	<p>020021111000</p>

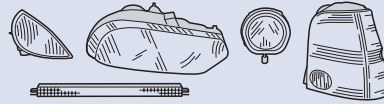
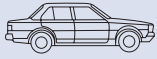

CODE

HEMA Tractor



99
↓

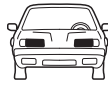

H4

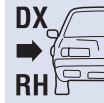

036648111000



036748111000

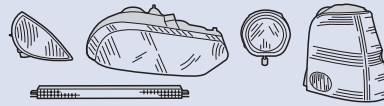
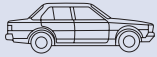

CODE

HONDA CRV



07
↓



H11

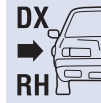

054530111000



054531111000

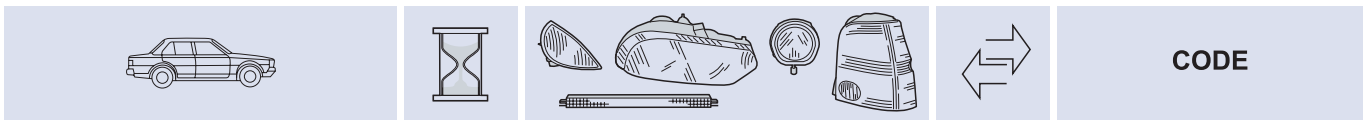

HYUNDAI Accent Admire

	07/03 ⇓ 05	 H4	 H4	 H4	DX RH	010051111000
			 H4	 H4	 H4	SX LH
	07/03 ⇓ 05	 	 	 	DX RH	020090111000
			 	 	 	SX LH

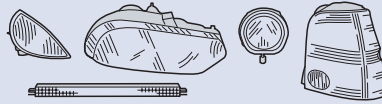
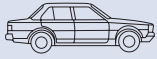

HYUNDAI Accent MC

	06 ⇓	 H4	 H4	 H4	DX RH	010190112000
			 H4	 H4	 H4	SX LH
 	06 ⇓	 	 	 	DX RH	010195112000
			 	 	 	SX LH
	06 ⇓	 	 	 	DX RH	020210112000
			 	 	 	SX LH



CODE





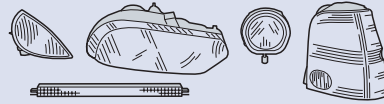
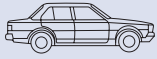















HYUNDAI Starex

	<p>05 ↓</p>	 <p>H1 H7</p>		<p>DX → RH</p>	<p>010110111000</p>
				<p>SX ← LH</p>	<p>010120111000</p>



CODE

ISIZU (Bus / Otobüs)

	<p>99</p> 	 <p>H4 H1</p>	<p>DX</p>  <p>RH</p>  <p>003115834111</p>
			<p>SX</p>  <p>LH</p>  <p>003125834111</p>
	<p>99</p> 	 <p>H1</p>	<p>DX</p>  <p>RH</p>  <p>036618171111</p>
			<p>SX</p>  <p>LH</p>  <p>036718171111</p>
	<p>99</p> 	 <p>H4</p>	<p>DX</p>  <p>RH</p>  <p>036648181111</p>
			<p>SX</p>  <p>LH</p>  <p>036748181111</p>

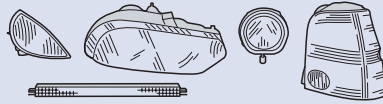
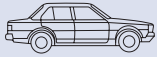

CODE

MERCEDES (W251) A, B, C, E Seri



07
↓



H11



040210111000





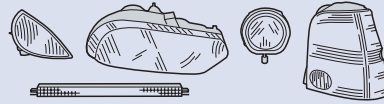
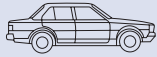











040220111000



CODE

OTOKAR Deutz - Magirus (Minibus / Minibüs)

	<p>99</p> 	 <p>H4</p>	<p>DX</p>  <p>RH</p> 	003099834111
			<p>SX</p>  <p>LH</p> 	003100834111
	<p>99</p> 	 <p>H1</p>	<p>DX</p>  <p>RH</p> 	003140834111
			<p>SX</p>  <p>LH</p> 	003110834111

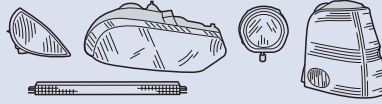
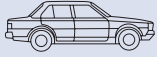

CODE

OTOYOL - IVECO (Truck / Kamyon)

	99 	 H4 H1	DX RH 	003980111000
			SX LH 	003990111000
	99 	 H1	DX RH 	036618160111
			SX LH 	036718160111
	99 	 H4	DX RH 	036648160111
			SX LH 	036748160111
	99 	 H1	DX RH 	032500722000
			SX LH 	





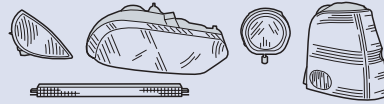
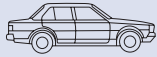

















OTOYOL - IVECO (Bus / Otobüs)

	99 	 H4 H1	DX RH 	003985111000
			SX LH 	003995111000



CODE





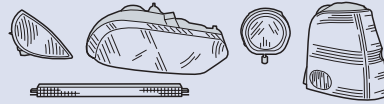
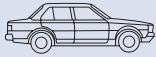













OTOYOL - IVECO (Bus / Otobüs)

	<p>99</p> 	 <p>H1</p>	<p>DX</p>  <p>RH</p> 	036718171111
			<p>SX</p>  <p>LH</p> 	036718171111
	<p>99</p> 	 <p>H4</p>	<p>DX</p>  <p>RH</p> 	036648171111
			<p>SX</p>  <p>LH</p> 	036748171111
	<p>99</p> 	  <p>H1</p>	<p>DX</p>  <p>RH</p> 	036841622000
			<p>SX</p>  <p>LH</p> 	036851622000















CODE

RENAULT 9

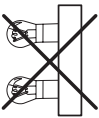

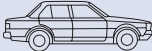

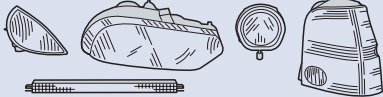
	06  01	 H4	DX  → RH 	038280111000
			 SX ← LH	038290111000
	06  01		DX  → RH 	038300111000
			 SX ← LH	038310111000
	98  01		DX  → RH 	038440111000
			 SX ← LH	038450111000

RENAULT 19 - Chamade

	94  01	 4 DOORS	DX  → RH 	037420111000
			 SX ← LH	037430111000
	94  01	 4 DOORS		037440111000

				CODE
---	---	--	---	-------------



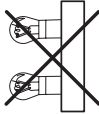













RENAULT 19 - Chamada

	94 ⇓ 01	 CENTR 4 DOORS		037440111000
	94 ⇓ 01	 CENTR 4 DOORS		037440111000

RENAULT 19 - Hatchback

		 CENTR 4 DOORS		070081690400
---	--	--	--	--------------

RENAULT Clio III (L65)

	02 ⇓	 H1 H7	 BLACK		DX   RH	010010112000
					SX   LH	010020112000
	02 ⇓	 H1 H7	 GREY		DX   RH	010012112000
					SX   LH	010022112000

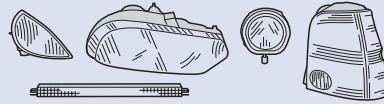
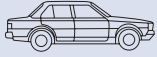

CODE

RENAULT Megane L84 (Ph2)

	<p>06</p>		<p>DX</p> <p>RH</p>	<p>020070111000</p>
			<p>SX</p> <p>LH</p>	<p>020080111000</p>
	<p>06</p>		<p>DX</p> <p>RH</p>	<p>020076112000</p>
			<p>SX</p> <p>LH</p>	<p>020086112000</p>





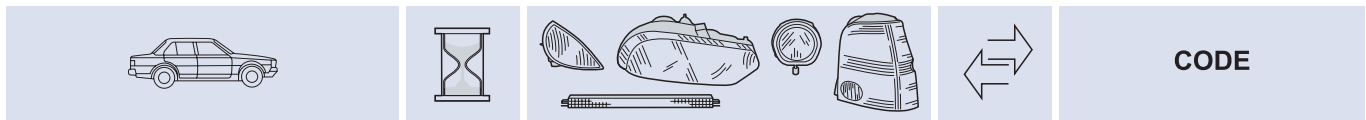





RENAULT Megane SW (K25)

	<p>98</p>		<p>DX</p> <p>RH</p>	<p>039690111000</p>
			<p>SX</p> <p>LH</p>	<p>039680111000</p>







CODE





PEUGEOT Bipper

	<p>07 ⇓</p>	 <p>H4</p> 	<p>DX →</p>  <p>RH</p>	<p>045560111000</p>
			<p>SX ←</p>  <p>LH</p>	<p>045570111000</p>
	<p>07 ⇓</p>	 <p>H4 RHD</p> 	<p>DX →</p>  <p>RH</p>	<p>045565111000</p>
			<p>SX ←</p>  <p>LH</p>	<p>045575111000</p>

PEUGEOT Bipper (Cargo)

	<p>07 ⇓</p>	 <p>H1</p> 	<p>DX →</p>  <p>RH</p>	<p>040250111000</p>
			<p>SX ←</p>  <p>LH</p>	





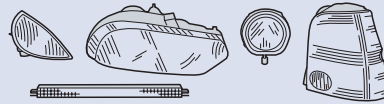







PEUGEOT Bipper (Combi)

	<p>07 ⇓</p>	 <p>H1</p> 	<p>DX →</p>  <p>RH</p>	<p>040255111000</p>
			<p>SX ←</p>  <p>LH</p>	<p>040260111000</p>



CODE

PEUGEOT Boxer

	<p>06</p> 		<p>DX</p>  <p>RH</p> 	<p>020150111000</p>
			<p>SX</p>  <p>LH</p> 	<p>020160111000</p>
<p>Tropic</p>	<p>06</p> 		<p>DX</p>  <p>RH</p> 	<p>020155111000</p>
			<p>SX</p>  <p>LH</p> 	<p>020165111000</p>

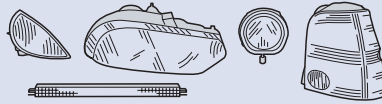
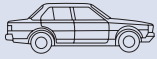

CODE

PEUGEOT 106 RY



03/96

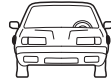

040325999000

PEUGEOT 306



12/97



040325999000

PEUGEOT 406 I

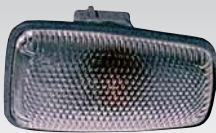

12/97



040325999000

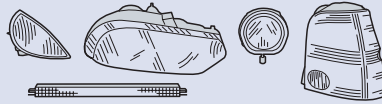
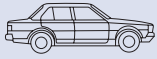

CODE

PEUGEOT 806 RY



01/99

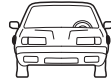

040325999000

PEUGEOT Partner



12/97





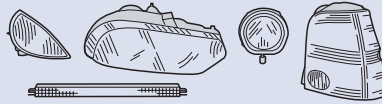
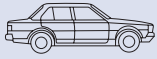



040325999000



CODE

TOYOTA Corolla

	<p>98 ⇓ 02</p>		<p>DX → RH</p> 	<p>081270125000</p>
	<p>98 ⇓ 02</p>		<p>DX → RH</p>  <p>SX ← LH</p> 	<p>81570121900</p>

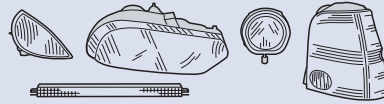
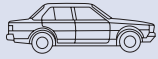

CODE

UZEL Massey Ferguson Tractor



03
↓



H4



010070111000

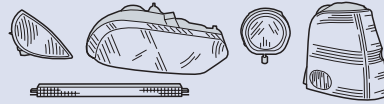
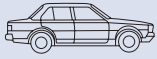

CODE

VOLVO (P1007)



07
↓



H11

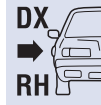

040230111000



040240111000

*Karşılaştırma Tablosu
Tavole di comparazione
Cross reference guide*

CROSS REFERANCE LIST / KARŞILAŞTIRMA LİSTESİ

MAKO	MAGNETTI MARELLI	VALEO	BOSCH	HELLA
010010112000	715030160596			
010012112000	712100121110			
010020112000	715030160595			
010022112000	712100221110			
016830111000	712168301110			
016831111000	712168311110			
016910964900	712169108999			
016911964900	712169118999			
020110111000	712201101110			
020120111000	712201201110			
020130111000	712201301110			
020135111000	712201351110			
020140111000	712201401110			
020145111000	712201451110			
020150111000	714028390801			
020160111000	714028390701			
033130212000	712331351129	084511	0318035114	
033140212000	712331451129	084510	0318035113	
033150211000	712331501110	084513	0318218204	
033160211000	712331601110	084512	0318218203	
033210211000	712332111110			
033220211000	712332211110			
033441112000	712334411110			
033451112000	712334511110			
033441111000		084326		
033451111000		084327		
033481111000	712334811110	084323	0318222204	
033491111000	712334911110	084325	0318222203	
033481211000	712334801110		0318222004	
033491211000	712334901110		0318222003	
033441113000	712334401110			
033451113000	712334501110			
033700111000	712368001129		0318417014	

CROSS REFERANCE LIST / KARŞILAŞTIRMA LİSTESİ

MAKO	MAGNETTI MARELLI	VALEO	BOSCH	HELLA
033710111000	712368101129		0318417013	
033700111000	712337001110		0318417004	
033710111000	712337101110		0318417003	
033900211000	712339001110		0318324204	
033910211000	712339101110		0318324203	
033940111000	712339401110		0318326204	
033950111000	712339501110		0318326203	
036340111000	712363401129	085237	0318220204	
036350111000	712363501129	085236	0318220203	
036840111000	712368401129		0318419004	
036850111000	712368501129		0318419003	
036880111000	712368801129	085233	0318037114	
036890111000	712368901129	085232	0318037113	
037420111000	712374201119	084812	0318340204	
037430111000	712374301119	084811	0318340203	
037440111000	712374401119	084815	0318340509	
038404111000	712384041110			
038405111000	712384051110			
038540111000	712385441129		0318034214	
038550111000	712385541129		0318034213	
038541111000	712385431129		0318034014	
038551111000	712385531129		0318034013	
038561111000	712385631129		0318213204	
038570111000	712385741129			
038571111000	712385731129		0318213203	
038600111000	712386001129			
038610111000	712386101129			
038620111000	712386201129		0318323004	
038630111000	712386301129		0318323003	
038640111000	712386401129			
038650111000	712386501129			
039130111000	712391301110			
039140111000	712391401110			

O.E CODE	MAKD [®] CODE	O.E CODE	MAKD [®] CODE
ALFA ROMEO		TOFAŞ / FIAT	
60692719	041070111000	518074130	020137111000
		51701589	020140111000
BMW		518074140	020147111000
7177712-06	040150111000	51718014	020136111000
7177711-06	040160111000	51718014	020145111000
7181288-04	040170111000	51718013	020146111000
7181284-04	040180111000	01344047080	020150111000
2751295-03	0400101110000	01355855080	020155111000
2751293-03	0400151110000	01344050080	020160111000
		01355856080	020165111000
CHRYSLER		51755144	020110111000
29324	010030111000	51755145	020120111000
29323	010040111000	518059340E	043680111000
		518059360E	043685111000
TOFAŞ / FIAT		518059350E	043690111000
779568	041070111000	77795368	041070111000
1353197080	045560111000	1353197080	045560111000
1356686080	045565111000	1356686080	045565111000
1353198080	045570111000	1353198080	045570111000
1356687080	045575111000	1356687080	045575111000
1356651080E	040250111000	1356651080E	040250111000
1356780080E	040255111000	1356780080E	040255111000
1357925080E	040260111000	1357925080E	040260111000
51776317	045220111000	51776317	045220111000
51751879	045225111000	51751879	045225111000
51776318	045230111000	51776318	045230111000
51752445	045235111000	51752445	045235111000
51753752	020190111000	51753752	020190111000
51795132	020195111000	51795132	020195111000
51753758	020200111000	51753758	020200111000
51795133	020205111000	51795133	020205111000
51701590	020130111000	51701590	020130111000
51718012	020135111000	51718012	020135111000

O.E CODE	MAKO [®] CODE	O.E CODE	MAKO [®] CODE
TOFAŞ / FIAT		TOFAŞ / FIAT	
518059370E	043695111000	7642681	033441112000
518074130	020137111000	7642682	033451112000
51701589	020140111000	9943193	033481111000
518074140	020147111000	9943194	033491111000
51718014	020136111000	7730046	033900211000
51718014	020145111000	7730047	033910211000
51718013	020146111000	7700414	033940111000
01344047080	020150111000	7700413	033950111000
01355855080	020155111000	46710862	036880111000
01344050080	020160111000	46710861	036890111000
01355856080	020165111000	46710870	036340111000
51755144	020110111000	46710869	036350111000
51755145	020120111000	7762890	036840111000
518059340E	043680111000	7762889	036850111000
518059360E	043685111000	7762888	033700111000
518059350E	043690111000	465371110	038540111000
518059370E	043695111000	465371120	038550111000
51775551	045380111000	7762887	033710111000
51775550	045390111000	46537828	038561111000
517377210E	041500111000	46537829	038571111000
51809413	041505111000	46434794	038600111000
517377220E	041510111000	46344792	038610111000
51809414	041515111000	46434789	038620111000
517377230E	041520111000	46434790	038630111000
51809415	041525111000	46537830	038640111000
517377240E	041530111000	46537831	038650111000
51809416	041535111000	46540161	040020111000
7678223	033130212000	46540162	040030111000
7678224	033140212000	735252740	040060111000
9943062	033150211000	46807772	040540111000
9943063	033160211000	46807766	040545111000
7592548	033210211000	46807771	040550111000
7592553	033220211000	46807765	040555111000

O.E CODE	MAKO [®] CODE	O.E CODE	MAKO [®] CODE
TOFAŞ / FIAT		FORD OTOSAN	
7785368	041070111000	9 EL 157578-031	054595551111
46434794	038600111000	9 EL 157578-041	054595552111
46344792	038610111000	9 EL 157578-011	038404111000
735252740	040060111000	9 EL 157578-021	038405111000
7642682	033451112000	2T14-13005-AD	039140111000
7592559	033220211000	2T14-13005-BD	039145111000
46434789	038620111000		
46434790	038630111000	HONDA	
465371110	038540111000	33900-SWW	040110111000
465371120	038550111000	33950-SWW	040120111000
46540161	040020111000		
46540162	040030111000	HYUNDAI	
46537828	038561111000	92102-1E088	010190112000
46537829	038571111000	92102-1E077	010195112000
46539510	038551111000	92101-1E088	010200112000
46537830	038640111000	92101-1E077	010205112000
46537831	038650111000	92402-1E088	020210112000
		92401-1E088	020220112000
FORD OTOSAN			
7242045	054530111000	MERCEDES	
7242051	054531111000	A-2518200856	040210111000
1 AC 008563-011	054530111000	A-2518200756	040220111000
1 AC 008563-021	054531111000		
6C11-13W029-DC	010090111000	RENAULT	
6C11-13W029-BC	010091111000	8200417347	020070111000
6C11-13W029-CC	010095111000	8200757701	020076112000
6C11-13W029-AC	010096111000	8200417345	020080111000
6C11-13W030-DC 1/8	010100111000	8200757700	020086112000
6C11-13W030-BC	010101111000	8200586844	020230111000
6C11-13W030-CC	010105111000	8200586843	020240111000
6C11-13W030-AC	010106111000	8200612622	020235111000
2T14-13006-AD	039130111000	8200728113	020236111000
2T14-13006-BD	039135111000	8200587313	020245111000



OUR DISTRIBUTORS / DİSTRİBÜTÖRLERİMİZ

BİRMOT

BİRLEŞİK MOTOR SANAYİ VE TİCARET.A.Ş.

Aydınevler Mah. Dumlupınar Cad. No:24 34854 Küçükyalı/İstanbul
Tel:(0216) 587 98 00 Fax:(0216) 417 12 89
www.birmot.com.tr

GALİP TİCARET

Şehit Muhtar Cad. Nur Apt. No,38/2 Kat 1 80090 Taksim / İSTANBUL
Tel: 0.212.237 20 15 - 237 20 16 - 250 59 45 - 254 12 91 4 hat Fax: 0212 -254 35 62 - 237 84 83
galipticaret@superonline.com

ÇELİKASLAN A.Ş.

İnönü Caddesi No.18 Kolejtepe / GAZİANTEP
Tel: 0.342.231 00 58 - 230 68 65 - 230 55 59 Fax: 0342.230 03 53
otomotiv@celikaslan.com

TAYPAR A. Ş.

Taksim Cad. No.71/73 80000 Taksim / İSTANBUL
Tel: 0.212.256 51 51 pbx Fax: 0.212.237 62 49
taypar@superonline.com

KARLAND

OTOMOTİV ÜRÜNLERİ SANAYİ VE TİCARET A. Ş.

Emek Mah. Ordu Cad. No.12 Sarıgazi-Ümraniye / İSTANBUL
Tel: 0.216.466 93 10 pbx Fax: 0.216.466 93 18
karland@karland.com.tr

ALİPAR OTOMOTİV

SANAYİ VE TİCARET LİMİTED ŞİRKETİ

2822. Sok. No.66 1. Sanayi sitesi / İZMİR
Tel: 0.232.433 72 57 - 458 34 58 - 433 90 60 Fax: 0.232.457 94 69
info@alipar.com

CEYLAN OTOMOTİV

Şaşmaz Oto Sanayi Sitesi
Bahçekapı Mah. 1. Cadde No.7 Etimesgut / ANKARA
Tel.: 0.312 278 44 03 pbx Fax: 0.312 278 55 84
ceylanotomotiv@hotmail.com

We illuminate the world...

MAKO®

Mako Elektrik Sanayi ve Ticaret A.Ş.
Organize Sanayi Bölgesi Yeşil Cad. No. 28 16159 Nilüfer / BURSA / TÜRKİYE
TEL.: +90 (0224) 219 56 00 (pbx) - FAX: +90 (0224) 219 57 99
www.mako.com.tr